



CARIBBEAN EXAMINATIONS COUNCIL

**Caribbean Secondary Education Certificate®
CSEC®**

PHYSICS SYLLABUS

Effective for examinations from May–June 2015

Published by the Caribbean Examinations Council.

All rights reserved. No part of this publication may be reproduced, stored in a retrieval system, or transmitted in any form, or by any means electronic, photocopying, recording or otherwise without prior permission of the author or publisher.

Correspondence related to the syllabus should be addressed to:

The Pro-Registrar
Caribbean Examinations Council
Caenwood Centre
37 Arnold Road, Kingston 5, Jamaica

Telephone Number: + 1 (876) 630-5200

Facsimile Number: + 1 (876) 967-4972

E-mail Address: cxcwzo@cxc.org

Website: www.cxc.org

Copyright © 2013 by Caribbean Examinations Council
The Garrison, St Michael BB14038, Barbados



Content

RATIONALE	1
AIMS.....	1
CANDIDATE POPULATION.....	2
SUGGESTED TIME-TABLE ALLOCATION	2
ORGANISATION OF THE SYLLABUS.....	3
SUGGESTIONS FOR TEACHING THE SYLLABUS.....	3
CERTIFICATION AND DEFINITION OF PROFILES.....	4
FORMAT OF THE EXAMINATION.....	5
REGULATIONS FOR PRIVATE CANDIDATES.....	6
REGULATIONS FOR RESIT	6
THE PRACTICAL APPROACH.....	7
SECTION A - MECHANICS.....	10
SECTION B - THERMAL PHYSICS AND KINETIC THEORY.....	21
SECTION C - WAVES AND OPTICS.....	28
SECTION D - ELECTRICITY AND MAGNETISM.....	35
SECTION E - THE PHYSICS OF THE ATOM.....	49
GUIDELINES FOR THE SCHOOL-BASED ASSESSMENT.....	53
LIST OF PHYSICAL QUANTITIES AND THEIR SYMBOLS.....	75
LIST OF GRAPHICAL SYMBOLS AS USED IN CIRCUIT DIAGRAMS.....	76
RECOMMENDED MINIMUM EQUIPMENT LIST.....	78
RESOURCES.....	80
GLOSSARY.....	81

This document CXC 22/G/SYLL 13 replaces CXC 22/G/SYLL 02 issued in 2002.

Please note that the syllabus has been revised and amendments are indicated by italics.

First published 1983

Reprinted with amendments 1986, 1987

Revised 1991, 1996, 2002, 2013

Please check the website www.cxc.org for updates on CXC's syllabuses.

Physics Syllabus

◆ RATIONALE

The application of scientific principles and the conduct of relevant research are of significant importance in identifying, assessing and realising the potential of the resources of Caribbean territories. A good foundation in the sciences will enhance the ability of our citizens to respond to the challenges of a rapidly changing world using the scientific approach.

Physics is a science that deals with matter and energy and their interactions. It is concerned with systems, laws, models, principles and theories that explain the physical behaviour of our world and the universe. Physics is regarded as a fundamental scientific discipline since all advances in technology can be traced either directly or indirectly to the physical laws and theories.

The CSEC Physics Syllabus is redesigned with a greater emphasis on the application of scientific concepts and principles. Such an approach is adopted in order to develop those long-term transferrable skills of ethical conduct, team work, problem solving, critical thinking, innovation and communication. In addition, it encourages the use of various teaching and learning strategies to inculcate these skills while, at the same time catering to multiple intelligences and different learning styles and needs. The syllabus will assist students to develop positive values and attitudes towards the physical components of the environment and will also provide a sound foundation for those who wish to pursue further studies in science.

It contributes to the development of the Ideal Caribbean Person as articulated by the CARICOM Heads of Government in the following areas: respect for human life; and awareness of the importance of living in harmony with the environment; demonstrates multiple literacies; independent and critical thinking and the innovative application of science and technology to problem solving. Such a person should demonstrate a positive work ethic and value and display creative imagination and entrepreneurship. In keeping with the UNESCO Pillars of Learning, on completion of the study of this course, students will learn to do, learn to be and learn to transform themselves and society.

◆ AIMS

This syllabus aims to:

1. *acquire technical and scientific vocabulary;*
2. *develop the ability to apply an understanding of the principles and concepts involved in Physics to situations which may or may not be familiar;*
3. *appreciate the contributions of some of the outstanding regional and international scientists to the development of Physics;*
4. *develop critical thinking and problem solving skills;*
5. *plan, design and perform experiments to test theories and hypotheses;*

6. *collect and represent data in an acceptable form;*
7. *report accurately and concisely;*
8. *develop the ability to appraise information critically, identify patterns, cause and effect, stability and change, and evaluate ideas;*
9. *develop the ability to work independently and collaboratively with others when necessary;*
10. *appreciate the significance and limitations of science in relation to social and economic development;*
11. *develop an awareness of the applications of scientific knowledge and a concern about the consequences of such applications, particularly the impact on the environment;*
12. *integrate Information and Communication Technology (ICT) tools and skills.*

◆ CANDIDATE POPULATION

The syllabus is designed for students intending to pursue further studies in science at the tertiary level as well as students whose formal study of the subject is unlikely to proceed further.

CANDIDATE REQUIREMENTS

1. Candidates should have been exposed to at least three years of science at the secondary level, which should provide an introduction to basic scientific principles.
2. Candidates should be concurrently studying or have done:
 - (a) CSEC Mathematics or its equivalent;
 - (b) CSEC English A (English Language) or its equivalent.

CLASS SIZE

It is recommended that practical classes accommodate approximately **twenty-five** candidates.

◆ SUGGESTED TIME-TABLE ALLOCATION

It is recommended that a minimum of five 40-minute periods per week, including one double period, be allocated to the subject over a two-year period.

◆ ORGANISATION OF THE SYLLABUS

The syllabus is arranged in *five* sections, namely:

SECTION A	-	Mechanics
SECTION B	-	Thermal Physics and Kinetic Theory
SECTION C	-	Waves and Optics
SECTION D	-	Electricity and Magnetism
SECTION E	-	The Physics of the Atom

◆ SUGGESTIONS FOR TEACHING THE SYLLABUS

It is recommended that Section A be taught first.

The organisation of each section in the syllabus is designed to facilitate inquiry-based learning and to ensure that connections among physical concepts are established. Teachers should ensure that their lessons stimulate the use of the senses in learning as this will help students view science as a dynamic and exciting investigative process.

The general and specific objectives indicate the scope of the content including practical work that should be covered. However, unfamiliar situations may be presented as stimulus material in examination questions.

This syllabus caters to varying teaching and learning styles, with specific attention made to ensure the interrelatedness of concepts. The fourth column entitled, “Skills and Interrelationships” states which specific objectives are best suited for Observation, Recording and Reporting (ORR), Manipulation and Measurement (MM), Analysis and Interpretation (AI), and Planning and Designing (PD) skills. Whenever possible, a practical approach should be employed, with special attention given to the identification of variables and the use of information gathering technological tools and social networking media to aid investigations and team work. The need for good observational, mathematical, data analysis and reporting skills must be emphasised.

Column four also highlights connections between physical concepts and the fields of Chemistry, Biology, Mathematics and other related disciplines. In order to make the course as relevant as possible, students’ awareness of the effect of science and technology on society and environment and vice versa should be encouraged.

While classical Physics is several hundred years old, it is the fundamental discipline responsible for the modern technological era we live in and a strong appreciation of this must be inculcated by linking the work of the classical scientists to the present technological development.

Greater emphasis should be placed on the application of scientific concepts and principles and less on the factual materials, which encourage memorisation and short-term recall. Every opportunity should be made to relate the study of physical principles to relevant, regional and global examples. The relationship between the theory and practical is to be continually highlighted.

The role of the teacher is to facilitate students' learning of accurate and unbiased information that will contribute to a more scientifically literate society, capable of making educated decisions regarding the world we live in.

◆ CERTIFICATION AND DEFINITION OF PROFILES

The syllabus will be examined for General Proficiency certification.

In addition to the overall grade, there will be a profile report on the candidate's performance under the following headings:

1. Knowledge and Comprehension.
2. Use of Knowledge.
3. Experimental Skills.

Knowledge and Comprehension (KC)

	The ability to:
Knowledge	identify, remember and grasp the meaning of basic facts, concepts and principles;
Comprehension	select appropriate ideas, match, compare and cite examples of facts, concepts and principles in familiar situations.

Use of Knowledge (UK)

	The ability to:
Application	use facts, concepts, principles and procedures in unfamiliar situations; transform data accurately and appropriately; use formulae accurately for computations;
Analysis and Interpretation	identify and recognise the component parts of a whole and interpret the relationship between those parts; identify causal factors and show how they interact with each other; infer, predict and draw conclusions; make necessary and accurate calculations and recognise the limitations and assumptions inherent in the collection and interpretation of data;
Synthesis	combine component parts to form a new meaningful whole; make predictions and solve problems;
Evaluation	make reasoned judgments and recommendations based on the value of ideas and information and their implications.

Experimental Skills (XS)

The ability to:

Observation/Recording/ Reporting	select observations relevant to the particular activity; record the result of a measurement accurately; select, draw and use appropriate models of presenting data, for example, tables, graphs and diagrams; organise and present a complete report in a clear and logical form; report accurately and concisely; report and recheck unexpected results;
Manipulation/Measurement	follow instructions; set up and use carefully and competently simple laboratory apparatus and measuring instruments;
Planning and Designing	develop hypotheses and devise means of carrying out investigations to test them; plan and execute experimental procedures and operations in an appropriate sequence; use controls where appropriate; modify original plan or sequence of operations as a result of difficulties encountered in carrying out experiments or obtaining unexpected results; take into account possible sources of error, precautions and limitations in the design of an experiment.

◆ **FORMAT OF THE EXAMINATION**

Paper 01 (1 hour 15 minutes)	An objective test consisting of 60 multiple choice items.
Paper 02 (2 hours 30 minutes)	One compulsory data analysis question, two structured questions and three extended response questions.
Paper 03/1 School-Based Assessment (SBA)	School-Based Assessment will evaluate the achievement of the candidate in the Experimental Skills and Analysis and Interpretation involved in the laboratory and fieldwork. Candidates will be required to keep a separate practical workbook which must be made available for moderation.
Paper 03/2 Assessment for Private candidates only (2 hours and 10 minutes)	Alternate to the School-Based Assessment for private candidates. This paper will examine the same skills as those tested in Paper 03/1. The focus, therefore, will be on Experimental Skills, Analysis and Interpretation and Use of Knowledge.

NOTES ON THE EXAMINATION

1. The use of silent non programmable calculators will be allowed. The use of a calculator to previously store and then recall information during an examination is prohibited.
2. SI units will be used on all examination papers.

WEIGHTING OF PAPERS AND PROFILES

The percentage weighting of the examination components and profiles is as follows:

Table 1 – Percentage Weighting of Papers and Profiles

PROFILES	PAPER 1 Multiple Choice	PAPER 2 Structured and Data Analysis	PAPER 3 SBA	TOTAL RAW SBA	TOTAL %
Knowledge and Comprehension	50	35	-	85	43
Use of Knowledge	10	55	10	75	37
Experimental Skills	–	10	30	40	20
TOTAL %	60	100	40	200	100

◆ REGULATIONS FOR PRIVATE CANDIDATES

Private candidates must be entered for examination through the Local Registrar in their respective territories and will be required to sit Papers 01, 02, and EITHER Paper 03/1 OR Paper 03/2.

Paper 03/2 is a practical examination designed for candidates whose work cannot be monitored by tutors in recognised educational institutions. The Paper will be of 2 hours and 10 minutes duration and will consist of three questions. Questions will test the Experimental Skills and Use of Knowledge (Analysis and Interpretation) profiles and will incorporate written exercises and practical activities.

◆ REGULATIONS FOR RESIT CANDIDATES

Resit candidates must complete Papers 01 and 02 and Paper 03 of the examination for the year for which they re-register. Resit candidates may elect not to repeat the School-Based Assessment component, provided they re-write the examination no later than two years following their first attempt.

Candidates may opt to complete the School-Based Assessment (SBA) or may opt to re-use another SBA score which satisfies the condition below.

A candidate who re-writes the examination within two years may re-use the moderated SBA score earned in the previous sitting within the preceding two years. Candidates re-using SBA scores in this way must register as “Resit candidates” and provide the previous candidate number.

All resit candidates may enter through schools, recognized educational institutions, or the Local Registrar’s Office.

◆ THE PRACTICAL APPROACH

The syllabus is designed to foster the use of inquiry-based learning through the application of the practical approach. Students will be guided to answer scientific questions by a process of making observations, asking questions, doing experiments, and analysing and interpreting data. The CXC CSEC Physics syllabus focuses on the following skills.

1. Planning and Designing (PD)

Student's ability to:

- (a) Ask questions: how, what, which, why or where. (Students must be guided by their teachers to ask scientific questions).

Example: How does the length of the simple pendulum affect its period of swing?

- (b) Construct a hypothesis: The hypothesis must be clear, concise and testable.

Example: There is direct correlation between the length of the pendulum and period of the swing.

- (c) Design an experiment to test the hypothesis. Experimental report must include the following:

- (i) problem statement;
- (ii) aim;
- (iii) list of materials and apparatus to be used;
- (iv) identification of variables;
- (v) clear and concise step by step procedure;
- (vi) display of expected results;
- (vii) use of results;
- (viii) possible sources of error/precaution;
- (ix) possible limitations.

2. Measurement and Manipulation (MM)

- (a) Student's ability to handle scientific equipment competently.

The list of equipment is:

- (i) Bunsen burner;
- (ii) Vernier callipers;
- (iii) measuring cylinder;

- (iv) *beakers;*
- (v) *thermometer;*
- (vi) *ruler;*
- (vii) *stop watch/clock;*
- (viii) *balance;*
- (ix) *micrometer screw gauge;*
- (x) *voltmeter;*
- (xi) *multimeter;*
- (xii) *ammeter.*

(b) *Student's ability to take accurate measurements.*

(c) *Student's ability to use appropriate units.*

3. *Observation, Reporting and Recording (ORR)*

(a) *Recording*

Student's ability to record observations and to collect and organise data; observations and data may be recorded in:

- (i) *Prose*
Written description of observations in the correct tense.
- (ii) *Table*
Numerical: physical quantities with symbols and units stated in heading, significant figures.
- (iii) *Graph*
Title axes labelled, correct scales, accurate plotting fine points, smooth curves/best fit lines.
- (iv) *Calculations*
Calculations must be shown with attention paid to units.

(b) *Reporting*

Student's ability to prepare a comprehensive written report on their assignments using the following format.

- (i) **Date** *(date of experiment).*
- (ii) **Aim** *(what is to be accomplished by doing the experiment).*

- (iii) **Apparatus and Materials** (all equipment and materials used in the experiment must be listed).
- (iv) **Method/Experimental Procedure** (step by step procedure written in the past tense).
- (v) **Results and Observations** (see (a) above: Recording).
- (vi) **Discussion and Conclusion** (see 4: Analysis and Interpretation).

4. Analysis and Interpretation

Student's ability to:

- (a) make accurate calculations;
- (b) identify patterns and trends, cause and effect, and stability and change ;
- (c) compare actual results with expected results if they are different;
- (d) identify limitations and sources of error and error ranges if appropriate;
- (e) suggest alternative methods or modification to existing methods;
- (f) draw a conclusion justified by data.

◆ SECTION A – MECHANICS

Mechanics is the branch of physics which deals with the study of motion. This section introduces the scientific method, physical measurements, significant figures and units, which transcends the entire syllabus.

GENERAL OBJECTIVES

On completion of this Section, students should:

1. *understand the importance of measurement and graphical representation of data;*
2. *appreciate the difference between scalar and vector quantities;*
3. *be familiar with the various effects of forces;*
4. *appreciate the universal applicability of the laws of dynamics and the conservation of momentum;*
5. *understand the significance of the concept of energy;*
6. *be aware of the application of hydrostatics in everyday life.*

SPECIFIC OBJECTIVES	CONTENT/ EXPLANATORY NOTES	SUGGESTED PRACTICAL ACTIVITIES	SKILLS AND INTER- RELATIONSHIP
1. SCIENTIFIC METHOD			

Students should be able to:

Galileo

- | | | | |
|---|---|--|--|
| 1.1 <i>discuss how the methodology employed by Galileo contributed to the development of Physics;</i> | <i>Relate the scientific method to the methodology employed by Galileo.</i> | | |
|---|---|--|--|

Simple Pendulum

- | | | | |
|--|--|--|---|
| 1.2 <i>investigate the factors which might affect the period of a simple pendulum;</i> | <i>Restrict factors to length of string, mass of bob, angle of displacement.</i> | <i>Take readings of the period for the variation of the different factors.</i> | <i>Skills: MM; ORR; AI; PD.</i> |
| 1.3 <i>use graphs of experimental data from simple pendulum;</i> | <i>Use \odot or \times to denote plotted points.</i> | <i>Allow students to plot T vs L and T^2 vs L.</i> | <i>Mathematics-
Functions,
Relations and
Graphs
Skill: ORR.</i> |

SECTION A – MECHANICS (cont'd)

SPECIFIC OBJECTIVES	CONTENT/ EXPLANATORY NOTES	SUGGESTED PRACTICAL ACTIVITIES	SKILLS AND INTER- RELATIONSHIP
Students should be able to:			
1.4	<i>draw a line of 'best fit' for a set of plotted values;</i>	<i>Reasons why 'best fit' line is the 'best' average of the data.</i>	<i>Skill: AI.</i>
1.5	<i>determine the gradient of the straight line graph;</i>	<i>Use a triangle that covers at least half of the 'best fit' line.</i> <i>Include the derivation of the unit of the gradient.</i>	<i>Mathematics – Functions, Relations and Graphs.</i>

MEASUREMENT

1.6	<i>express the result of a measurement or calculation to an appropriate number of significant figures;</i>	<i>Refer to SO A 1.5.</i>	<i>Mathematics.</i>
1.7	<i>discuss possible types and sources of error in any measurement;</i>	<i>Include those made with digital instruments, and ways of reducing such errors.</i>	
1.8	<i>use a variety of instruments to measure different quantities;</i>	<i>Measurements should include length – rulers, vernier calipers, micrometer screw gauge; units.</i> <i>Mass – balances; units.</i> <i>Time – clocks, stop clocks or watches; units.</i> <i>Volume – measuring cylinder; units.</i>	<i>Skill: MM.</i>
1.9	<i>assess the suitability of instruments on the basis of sensitivity, accuracy and range;</i>	<i>Similar instruments should be compared in the discussion.</i>	<i>Comparison of readings for the same quantity.</i> <i>Skill: MM.</i>

SECTION A – MECHANICS (cont'd)

SPECIFIC OBJECTIVES	CONTENT/ EXPLANATORY NOTES	SUGGESTED PRACTICAL ACTIVITIES	SKILLS AND INTER- RELATIONSHIP
Students should be able to:			
1.10	apply the formula for density: $\rho = \frac{m}{V}$.	Deduce unit.	Determine the density of regular and irregular solids and a liquid.
2. VECTORS			
2.1	distinguish between scalars and vectors and give examples of each;	Everyday examples for each type, for example, movement of a hurricane as vector. Mass of objects as scalar.	
2.2	use scale diagrams to find the resultant of two vectors;	Oblique vectors included.	Mathematics- Vectors.
2.3	calculate the resultant of vectors which are parallel, anti-parallel and perpendicular;	Limit calculations to four or less vectors.	Mathematics - Trigonometry. Skills: MM; AI.
2.4	explain that a single vector is equivalent to two other vectors at right angles.	Everyday examples of motion and force, for example, velocity of a ball thrown through the air.	Using single pulleys and masses against a grid board. Mathematics - Vectors.
3. STATICS			
<u>Forces, F</u>			
3.1	explain the effects of forces;	A force can cause a change in the size, shape or motion of a body.	Use plasticene and marbles to demonstrate effect of forces. Biology Movement Chemistry Bonding. Skills: MM; AI.

SECTION A – MECHANICS (cont'd)

SPECIFIC OBJECTIVES	CONTENT/ EXPLANATORY NOTES	SUGGESTED PRACTICAL ACTIVITIES	SKILLS AND INTER- RELATIONSHIP
Students should be able to:			
3.2 identify types of forces;	Situations in which electric, magnetic, nuclear or gravitational forces act.	Use magnets, falling objects. Static electricity.	Chemistry – Nuclear force. Skills: ORR., MM.
3.3 determine the weight of objects;	Weight = mass \times gravitational field strength: $W = mg$ On earth, $g = 10 \text{ Nkg}^{-1}$ Note that: $\text{Nkg}^{-1} \equiv \text{ms}^{-2}$.	Measure mass and weight for different objects. Plot a graph of weight vs mass. Determine the gradient.	Skills: MM; ORR; AI.
3.4 show how derived quantities and their related units are produced;	Note how unit p may be derived by multiplying and dividing fundamental quantities and their units; From the definition of the quantity, for example: $\text{N} \equiv \text{kgms}^{-2}$.		Mathematics- Algebra.
3.5 recall the special names given to the units for some derived quantities;	$\text{kgms}^{-2} = \text{N}$.		
3.6 express derived units using the index notation;		Conversion of units for given quantities into base units.	Biology - All measurements Chemistry - All measurements Mathematics- measurement.
3.7 identify situations in which the application of a force will result in a turning effect;	Situations that are relevant to everyday life, for example, opening a door, sitting on a 'seesaw', using a spanner.		

SECTION A – MECHANICS (cont'd)

SPECIFIC OBJECTIVES	CONTENT/ EXPLANATORY NOTES	SUGGESTED PRACTICAL ACTIVITIES	SKILLS AND INTER- RELATIONSHIP	
Students should be able to:				
<u>Turning Forces</u>				
3.8	<i>define the moment of a force, T;</i>	<i>Moment units of Nm. Note that Nm is not equivalent to a Joule. Refer to SO A3.4 - 3.6.</i>	<i>Perform simple experiments to investigate the turning effects of forces on bodies in equilibrium.</i>	<i>Skills: MM; ORR; AI.</i>
3.9	<i>apply the principle of moments;</i>	<i>Oblique forces are excluded. Use of measuring instruments to indicate the magnitude of the forces in equilibrium.</i>	<i>Observe situations in which forces are in equilibrium (varied to give different equilibrium situations).</i>	
3.10	<i>explain the action of common tools and devices as levers;</i>	<i>Identification of load, effort and fulcrum for each device and tool in use.</i>	<i>Hammers or spanners of different lengths, bottle openers, crowbars.</i>	<i>Biology- Movement in limbs.</i>
3.11	<i>determine the location of the centre of gravity of a body;</i>	<i>Centre of gravity of a variety of regular and irregular shaped solids, including lamina.</i>	<i>Find the centre of gravity for the given objects. Plumbline for lamina.</i>	<i>Skill: MM.</i>
3.12	<i>relate the stability of an object to the position of its centre of gravity and its weight;</i>	<i>The orientation of an object can change the position or height of its centre of gravity and affect its stability.</i>	<i>Compare the stability of the same regular solid, for example, cylinder, metre rule, cuboid in different positions, for example, horizontal, vertical, inclined.</i>	<i>Biology-Structure of the human body.</i>
<u>Deformation</u>				
3.13	<i>investigate the relationship between extension and force;</i>	<i>Interpretation of simple force-extension graphs. Identification of regions of proportionality for springs.</i>	<i>Perform experiments to determine the relationship between applied force and the resulting extensions, for springs and elastic bands.</i>	<i>Chemistry- Properties of materials. Mathematics Proportionality. Skills: MM; ORR; AI; PD.</i>

SECTION A – MECHANICS (cont'd)

SPECIFIC OBJECTIVES	CONTENT/ EXPLANATORY NOTES	SUGGESTED PRACTICAL ACTIVITIES	SKILLS AND INTER- RELATIONSHIP
---------------------	----------------------------------	--------------------------------------	--------------------------------------

Students should be able to:

- 3.14 *solve problems using Hooke's law.* *Problems involving springs and elastic bands only.*

4. DYNAMICS: MOTION IN A STRAIGHT LINE

- | | | | | |
|-----|---|---|---------------------------------------|---|
| 4.1 | <i>define the terms: distance, displacement, speed, velocity, acceleration;</i> | <i>Distance and displacement, s or x; speed and velocity, v; acceleration, $a = \frac{v-u}{t}$.</i> | <i>Trolleys on inclined plane.</i> | <i>Mathematics – Algebra/ Computation.

Skills: MM;AI;PD.</i> |
| 4.2 | <i>apply displacement-time and velocity-time graphs;</i> | <i>Finding the gradient for straight lines only.</i> | <i>Ticker tape timer, car racing.</i> | <i>Mathematics – Functions, Relations and Graphs.

Skills: ORR; AI.</i> |

Aristotle

- | | | | | |
|-----|--|--|--|--|
| 4.3 | <i>discuss Aristotle's arguments in support of his "law of motion", that is, $v \propto F$;</i> | <i>Aristotle's law was eventually discredited.</i> | <i>Push trolley on a flat surface.</i> | |
|-----|--|--|--|--|

Newton's Laws

- | | | | | |
|------|--|---|--------------------------------------|-------------------|
| 4.4 | <i>state Newton's three laws of motion;</i> | <i>Have students identify applicable laws after viewing examples.</i> | <i>Marbles in a groove.</i> | |
| 4.5. | <i>use Newton's laws to explain dynamic systems;</i> | <i>Examples - rockets, garden sprinklers, trampolines.</i> | | <i>Skill: AI.</i> |
| 4.6 | <i>define linear momentum;</i> | <i>Units of $\text{kg ms}^{-1} \equiv \text{Ns}$.</i> | | |
| 4.7 | <i>define linear momentum describe situations that demonstrate the law of conservation of linear momentum;</i> | | <i>Collisions of Billiard balls.</i> | |

SECTION A – MECHANICS (cont'd)

SPECIFIC OBJECTIVES	CONTENT/ EXPLANATORY NOTES	SUGGESTED PRACTICAL ACTIVITIES	SKILLS AND INTER- RELATIONSHIP
Students should be able to:			
4.8	<i>apply the law of conservation of linear momentum.</i>	<i>Oblique collisions are excluded.</i>	<i>Collisions between objects of different sizes or velocity.</i>
5.	ENERGY		
<u>Forms of Energy</u>			
5.1	<i>define energy;</i>	<i>Unit: Joule.</i>	
5.2	<i>identify the various forms of energy;</i>	<i>Gravitational, elastic, chemical, electrical, magnetic, electro-magnetic, thermal, nuclear, kinetic, sound.</i>	
5.3	<i>describe the energy transformation(s) in a given situation;</i>	<i>Transformations should be limited to one-step or two-step only. Note that thermal energy is always a product and by-product of every transformation. Examples of the conversion of electrical energy to other forms and vice versa.</i>	<i>Observe and list the energy transformations for the particular situation, for example, radio playing music, vehicles coming to rest, cooking food in microwave oven.</i>
5.4	<i>apply the relationship: work = force x displacement;</i>	<i>Unit: Joule.</i>	<i>Biology - Food web, Photosynthesis, Respiration. Chemistry-Burning of hydrocarbons.</i>
5.5	<i>discuss the use of energy from alternative sources, and its importance to the Caribbean;</i>	<i>Emphasis on examples relevant to the Caribbean, to include hydroelectricity, geothermal energy, tidal energy waves, solar energy, wind energy, nuclear energy. More efficient and economical use of energy.</i>	<i>Mathematics-Algebra/computation.</i>
		<i>Project on alternative energy sources.</i>	<i>Biology-Food web. Chemistry-Burning of hydrocarbons.</i>

SECTION A – MECHANICS (cont'd)

SPECIFIC OBJECTIVES	CONTENT/ EXPLANATORY NOTES	SUGGESTED PRACTICAL ACTIVITIES	SKILLS AND INTER- RELATIONSHIP
Students should be able to:			
<u>Potential Energy, E_p</u>			
5.6	define potential energy;	Examples of this form of energy, for example, battery, stretched spring or elastic band, object on shelf.	Skill: AI.
5.7	calculate the change in gravitational potential energy using: $\Delta E_p = mg\Delta h$;		Mathematics- Algebra/ Computation
<u>Kinetic Energy, E_k</u>			
5.8	define kinetic energy;	Definition. Give everyday examples.	Skill: AI.
5.9	calculate kinetic energies using the expression: $E_k = \frac{1}{2}mv^2$;		Mathematics- Algebra/ Computation
<u>Conservation</u>			
5.10	apply the law of conservation of energy;	Use different energy forms in these problems. Conversion of P.E. to K.E. on a moving swing, pendulum, kicking a football.	Skill: AI.
<u>Power, P</u>			
5.11	define power and apply definition;	Unit: Watt Apply: $P = \frac{E}{t}$. Refer to SO D3.3.	Perform activities to find the power in situations for which the energies and time intervals involved can be measured or calculated. Skills: MM; ORR; AI.

SECTION A – MECHANICS (cont'd)

SPECIFIC OBJECTIVES	CONTENT/ EXPLANATORY NOTES	SUGGESTED PRACTICAL ACTIVITIES	SKILLS AND INTER- RELATIONSHIP
Students should be able to:			
5.12	<i>explain the term efficiency;</i>	<i>The factors which affect its value.</i>	<i>Mathematics- Computation.</i>
5.13	<i>calculate efficiency in given situations.</i>	<i>Efficiency = $\frac{\text{output value}}{\text{input value}}$ x 100%</i>	<i>Skill: AI.</i>
6.	HYDROSTATICS		
6.1	<i>define pressure and apply definition;</i>	Apply: $P = \frac{F}{A}$. Refer to SO A3.5.	Pressure extended standing on one foot. <i>Mathematics- Algebra/ Computation. Skill: MM; ORR; AI.</i>
6.2	<i>relate the pressure at a point in a fluid to its depth and the density;</i>	Apply: $\Delta p = \rho g \Delta h$ (for fluid pressure); (Pascal) $\text{Pa} \equiv \text{Nm}^{-2}$. <i>All points on the same horizontal level in a fluid at rest, have the same pressure.</i>	<i>Demonstrate using a can with holes at same and at different levels, to illustrate the principle.</i> <i>Mathematics- Algebra/ Computation. Skill: MM.</i>
6.3	<i>apply Archimedes' principle to predict whether a body would float or sink in a given fluid.</i>	<i>Relevant examples include rafts, boats, balloons, and submarines.</i>	<i>Perform activities to check predictions.</i> <i>Biology - Dispersal of seeds.</i> <i>Skills: MM; ORR; AI; PD.</i>

Suggested Teaching and Learning Activities

To facilitate students' attainment of the objectives of this Section, teachers are advised to engage students in the teaching and learning activities below. These activities are designed to promote inquiry-based learning and cater to students with various learning styles.

1. **Galileo:** Galileo has been called the "father of modern observational Astronomy", the "father of Modern Physics", and the "father of science". Do group research projects on what his different contributions were to Science to earn him all these titles.

SECTION A – MECHANICS (cont'd)

2. **Scientific method:** Galileo made the important discovery that sunspots were on the surface of the sun by extremely patient and detailed daily observations of the Sun. Explain why this technique is critical to scientific study, even today.

“Galileo: Sunspots” by NOVA can be viewed as a class project

<http://www.teachersdomain.org/resource/ess05.sci.ess.eiu.galileosun/>

3. **Effect of gravity:** Have students drop a heavy and a light book from the same height at the same time and observe if they land at the same time or not. Discussion should ensue about the leaning tower of Pisa experiment.

4. **Units:** Students should do a five-minute PowerPoint presentation on the failure of the \$125 Million Mars Climate orbiter mission, which was launched in 1999 due to a mix up of metric and imperial units. The importance of units in Physics should be emphasised through this exercise.

5. **Centre of gravity:** Is it easier or harder to balance a yardstick on your finger than a pencil or ruler? Experiment and try to figure out why. Can you make a pencil easier to balance on your finger by adding weight at the top? Explain. “Centre of gravity: Pencil balance” from ZOOM should be viewed as a class activity.

<http://www.teachersdomain.org/resource/phy03.sci.phys.mfw.zpencilbalance/>

6. **Hydrodynamics:** Write an essay on the history and design of submarines.

What will it take to make a floating toy submarine sink to the bottom of a bathtub? Conduct an experiment based on your understanding of the factors that influence an object's buoyancy to the test in this interactive brainteaser from the NOVA website.

<http://www.teachersdomain.org/resource/phy03.sci.phys.matter.buoqu/>

7. **Friction:** Design a mini poster on “shooting stars”. Explain why the meteors burn up in the atmosphere. List the major meteor showers and see how many “shooting stars” you can observe during a meteor shower.

8. **Gravity:** Do a research project on how the construction industry evolved to build modern day sky scrapers and why they could not be built in the past. The tallest constructions of the past were pyramids. Why did they have to have bigger bases the taller they were built?

<http://science.howstuffworks.com/engineering/structural/skyscraper1.htm>

9. **Laws of motion, momentum and energy:** Arrange a cricket match with the class divided into two teams. Subsequent to the match, discuss from principles of Physics why the winning team won and the losing team did not. Use the items listed in the paper “Physics of Cricket” to discuss your points.

<http://www.physics.usyd.edu.au/~cross/cricket.html>

SECTION A – MECHANICS (cont'd)

10. **Laws of motion, momentum and energy:** With the school's permission, have a water rocket display with your class. The students must write a paper explaining the Physics of the trajectories and patterns formed.
11. **Friction, turning forces:** Design a poster to explain why rally cars can drift around corners and Formula 1 cars do not.
12. **Pendulums:** Do five minute group presentations on clocks through the ages and how the pendulum is used to build the clocks.
13. **Vectors:** Conduct research on Caribbean icon and scientist Dr. Rudranath Capildeo.

<http://www.caribbean-icons.org/profiles/rudranath.capildeo.htm>

14. **Renewable energy:** Divide the class into groups with each group being assigned a different form of renewable energy to research and investigate its suitability in the Caribbean. Design scaled models of their renewable energy options assigned.

http://www.teachersdomain.org/resource/phy03.sci.engin.systems.lp_renew/

“What is the design process?”

<http://www.teachersdomain.org/resource/phy03.sci.engin.design.desprocess/caribbean-icons.org/profiles/rudranath.capildeo.htm>

◆ SECTION B - THERMAL PHYSICS AND KINETIC THEORY

Thermal physics is the study of heat, temperature and heat transfer. It can be explained in terms of kinetic theory at the microscopic level. It helps us to capture the different phases of matter.

GENERAL OBJECTIVES

On completion of this Section, students should:

1. *be familiar with the development of the theory of heat;*
2. *relate macroscopic phenomena to the kinetic theory of matter;*
3. *have a conceptual understanding of thermal quantities and the relationship between them;*
4. *understand the various modes of thermal energy transfer.*

SPECIFIC OBJECTIVES	CONTENT/ EXPLANATORY NOTES	SUGGESTED PRACTICAL ACTIVITIES	SKILLS AND INTER- RELATIONSHIP
---------------------	----------------------------------	--------------------------------------	--------------------------------------

Students should be able to:

1. NATURE OF HEAT

- | | | | |
|-----|--|--|--------------------|
| 1.1 | <i>differentiate between the caloric and kinetic theories of heat as they existed in the eighteenth century;</i> | <i>Rumford's cannon-boring experiments as evidence against the caloric theory.</i> | <i>Discussion.</i> |
| 1.2 | <i>discuss the role of Joule's experiments in establishing the principle of conservation of energy.</i> | | |

2. MACROSCOPIC PROPERTIES AND PHENOMENA

Temperature, T

- | | | | |
|-----|---|--|-------------------------|
| 2.1 | <i>relate temperature to the direction of net thermal energy transfer;</i> | <i>Temperature T, units.</i> | |
| 2.2 | <i>identify physical properties which vary with temperature and may be used as the basis for measuring temperature;</i> | <i>Perform activities to observe change in length of liquid column with temperature.</i> | <i>Skills: MM; ORR.</i> |

SECTION B - THERMAL PHYSICS AND KINETIC THEORY (cont'd)

SPECIFIC OBJECTIVES	CONTENT/ EXPLANATORY NOTES	SUGGESTED PRACTICAL ACTIVITIES	SKILLS AND INTER- RELATIONSHIP
Students should be able to:			
2.3 relate the use of a thermometer to its design;	Highlight design features which make a thermometer suitable for its particular task. Note temperature ranges for each.	Draw and explain design of: (a) laboratory thermometer; (b) clinical thermometer (c) thermocouple.	Chemistry and Biology – Thermometer.
2.4 define the fixed points on the Celsius scale;	Lower and upper fixed points.		
2.5 relate the temperature of a body to the kinetic energy of molecules;			
<u>Phases of Matter</u>			
2.6 distinguish among solids, liquids and gases;	Note the differences with respect to inter-molecular forces, motion of molecules, shape and volume of matter.		Chemistry- States of matter.
2.7 use the Kinetic theory to explain the different macroscopic properties of solids, liquids and gases;		Perform simple experiments to illustrate the existence of inter-molecular forces, for example, compression of a syringe containing a liquid.	Chemistry - Diffusion, osmosis, particulate nature of matter. Biology - Diffusion, osmosis.
<u>Expansion</u>			
2.8 explain observations of the effects of thermal expansion;	Telephone lines. Application of thermal expansion, for example, opening jars, carbonated beverages, creaking roofs.	Demonstrations which illustrate expansion of solids, liquids, for example, ball and ring, bar breaking, bimetallic strip.	Chemistry - Properties of materials. Skill: ORR.

SECTION B - THERMAL PHYSICS AND KINETIC THEORY (cont'd)

SPECIFIC OBJECTIVES	CONTENT/ EXPLANATORY NOTES	SUGGESTED PRACTICAL ACTIVITIES	SKILLS AND INTER- RELATIONSHIP
---------------------	----------------------------------	--------------------------------------	--------------------------------------

Students should be able to:

Gas Laws

2.9	relate graphs of pressure or volume against temperature to the establishment of the Kelvin temperature scale;	Experiments to investigate the relationships among pressure, volume and temperature of a gas.	Chemistry – Gas Laws. Skills: MM; ORR; AI.
2.10	use the relationship between Kelvin and Celsius scale. $T/K = \theta/^{\circ}C + 273$;		
2.11	apply the gas laws;	(a) Boyle's Law – $PV = \text{constant}$; (b) Charles' Law – $\frac{V}{T} = \text{constant}$; (c) Pressure Law – $\frac{P}{T} = \text{constant}$; (d) General Gas Law - $\frac{PV}{T} = \text{constant}$.	Virtual labs Use of trapped gas in sealed syringe; sealed U-tube. Chemistry. Mathematics- Algebra/ Computation. Skill: AI; ORR.
2.12	give qualitative explanations of the gas laws in terms of the Kinetic theory.	Explain gas pressure in terms of molecular motion.	

3. THERMAL MEASUREMENTS

Specific Heat Capacity, c

3.1	distinguish between specific heat capacity, 'c' and heat capacity 'C';	Note that specific heat capacity and heat capacity are related by the formula $C = mc$.	Chemistry – properties of materials.
3.2	apply the relationship $E_H = mc \Delta\theta$, or $E_H = mc \Delta T$;		Mathematics- Algebra/ Computation. Skill: AI.

SECTION B - THERMAL PHYSICS AND KINETIC THEORY (cont'd)

SPECIFIC OBJECTIVES	CONTENT/ EXPLANATORY NOTES	SUGGESTED PRACTICAL ACTIVITIES	SKILLS AND INTER- RELATIONSHIP	
Students should be able to:				
3.3	<i>determine the specific heat capacity of metals and liquids;</i>	<i>Use electrical method and method of mixtures.</i>	<i>Perform activities to measure specific heat capacity.</i>	<i>Skills: MM; ORR; AI; PD.</i>
<u>Specific Latent Heat, I</u>				
3.4	<i>demonstrate that temperature remains constant during a phase change;</i>		<i>Perform cooling curve demonstration, for example, candle wax.</i>	<i>Chemistry - Melting point of metals and non-metals, separation in mixtures, properties of materials.</i> <i>Skill: ORR.</i>
3.5	<i>apply the relationship $E_H = ml$;</i>		<i>Perform activity to determine the specific latent heat of fusion of ice, using method of mixtures with a container of negligible heat capacity.</i>	<i>Mathematics- Algebra/ Computation</i> <i>Skills: MM; ORR; AI; PD.</i>
3.6	<i>determine the specific latent heat of vaporization l_v, and fusion, l_f of water;</i>	<i>Unit: Jkg^{-1} Use an electrical method.</i>	<i>Perform activity to determine specific latent heat of fusion.</i>	<i>Skills: MM; ORR; AI.</i>
3.7	<i>distinguish between evaporation and boiling.</i>	<i>Use the Kinetic theory to explain evaporation and boiling.</i> <i>Give examples of application of cooling effect of evaporation - air conditioners, earthenware vessels, refrigerators, perspiration.</i>		<i>Biology – Homeostasis.</i>

SECTION B - THERMAL PHYSICS AND KINETIC THEORY (cont'd)

SPECIFIC OBJECTIVES	CONTENT/ EXPLANATORY NOTES	SUGGESTED PRACTICAL ACTIVITIES	SKILLS AND INTER- RELATIONSHIP
Students should be able to:			
4. TRANSFER OF THERMAL ENERGY			
4.1 explain the transfer of thermal energy by conduction;	Relate the fact that air is a very poor conductor to the insulation properties of certain materials, for example, expanded polystyrene, hollow blocks. Refer to SO B2.6.	Perform activity to compare qualitatively the thermal conductivities of different solids.	Skills: MM; ORR.
4.2 explain the transfer of thermal energy by convection;	Relate convection to common phenomena, for example, land and sea breezes.	Perform demonstrations to show convection in fluids.	
4.3 explain the transfer of thermal energy by radiation;	Recall that radiant energy is electromagnetic (infra-red).	Perform demonstration to show that radiant energy does not need a medium for transmission.	Chemistry-Use of solar energy.
4.4 conduct experiments to investigate the factors on which absorption and emission of radiation depend;	Factors limited to: (a) texture of surface (rough, smooth); (b) nature of surface (shiny, dull); (c) colour of surface (black, white); (d) area of surface.	Perform experiments to investigate such factors.	Skills: ORR; MM; AI; PD.
4.5 recall that good absorbers are good emitters;	Relate the phenomenon of radiation to common practices.		

SECTION B - THERMAL PHYSICS AND KINETIC THEORY (cont'd)

SPECIFIC OBJECTIVES	CONTENT/ EXPLANATORY NOTES	SUGGESTED PRACTICAL ACTIVITIES	SKILLS AND INTER- RELATIONSHIP
---------------------	----------------------------------	--------------------------------------	--------------------------------------

Students should be able to:

- | | | | |
|-----|--|--|--|
| 4.6 | relate the principles of thermal energy transfer to the design of devices. | Conduction, convection, radiation.

<i>Vacuum flask and solar water heater.
Explanation of the glass house (green house) effect, including role of atmospheric CO₂.
Global Warming.</i> | |
|-----|--|--|--|

Suggested Teaching and Learning Activities

To facilitate students' attainment of the objectives of this Section, teachers are advised to engage students in the teaching and learning activities below. These activities are designed to promote inquiry-based learning and cater to students with various learning styles.

1. **Expansion and contraction:** Do a short research paper on why the Columbia space shuttle disaster occurred in 2003, killing all persons on board. Highlight the role of thermodynamics in it.
2. **Heat:** Make a list of applications of infrared imaging. Some examples can be found from the US Geological survey website at <http://www.usgs.gov/science/>.

http://coolcosmos.ipac.caltech.edu/image_galleries/ir_zoo/lessons/background.html.
3. **Heat sensors:** What animals use infrared vision and how does it help them? Imagine you could see in infrared, do a sketch of what the classroom would look like through infrared goggles.
4. **Heat transfer:** In the Caribbean islands, note where air conditioning units are typically placed in rooms. In cold countries where will heaters be located in a room? Explain the choices from principles of Physics.
5. **Temperature:** Play the online educational game in identifying the range of temperatures in different scales.

<http://funphysics.jpl.nasa.gov/adventures/temperature-game.html>.
6. **Temperature:** The temperature of zero Kelvin cannot be attained but very interesting phenomena happen as you get closer and closer to that temperature. Design a poster highlighting the phenomena and its use in modern technology.

SECTION B - THERMAL PHYSICS AND KINETIC THEORY (cont'd)

7. **Temperature ranges:** Explore some of the extreme temperatures on the moon through this video clip on the moon and why that happens.

<http://www.teachersdomain.org/resource/ess05.sci.ess.eiu.extemp/>

8. **Phases:** The water cycle is the process that moves water around Earth. In this video segment adapted from ZOOM, cast members use a homemade solar still to mimic this natural process, separating pure water from a saltwater mixture. The class can make this homemade solar still as a project and see the processes of condensation and evaporation and its relevance on planet earth.

<http://www.teachersdomain.org/resource/ess05.sci.ess.watcyc.solarstill1/>

9. **Local scientist:** Create a small booklet highlighting the biography and the contribution of Professor O. Headley in applications of solar energy in the Caribbean.

caribbean-icons.org/science/index.htm

◆ SECTION C - WAVES AND OPTICS

Wave theory represents the branch of Physics that deals with wave processes. It is significant to the understanding of sound phenomena. Light, which is electromagnetic in origin, is fundamental to the understanding of optics.

GENERAL OBJECTIVES

On completion of this Section, students should:

1. appreciate that wave motion is a means of transferring energy and that there are certain features common to all waves;
2. understand the way in which sound waves are produced and propagated;
3. understand the properties of the electromagnetic spectrum;
4. be familiar with the historical development of the theory of light;
5. appreciate how a ray treatment facilitates the understanding of reflection and refraction of light waves.

SPECIFIC OBJECTIVES	CONTENT/ EXPLANATORY NOTES	SUGGESTED PRACTICAL ACTIVITIES	SKILLS AND INTER- RELATIONSHIP
---------------------	----------------------------------	--------------------------------------	--------------------------------------

Students should be able to:

1. WAVE MOTION

Types of Waves

1. 1	differentiate between types of waves;	Pulses, progressive waves, transverse and longitudinal waves.	Production of waves using springs and in ripple tanks. Draw diagrams of: (a) transverse waves in ripple tank and slinky spring; (b) longitudinal wave in a slinky spring. <i>Virtual simulations.</i>	<i>Skill: ORR.</i>
------	---------------------------------------	---	--	--------------------

SECTION C – WAVES AND OPTICS (cont'd)

SPECIFIC OBJECTIVES	CONTENT/ EXPLANATORY NOTES	SUGGESTED PRACTICAL ACTIVITIES	SKILLS AND INTER- RELATIONSHIP
---------------------	----------------------------------	--------------------------------------	--------------------------------------

Students should be able to:

Wave Parameters

1.2	<i>apply speed, frequency, wavelength, period and amplitude;</i>	<i>Use: $v = f \lambda$. Refer to SO D2.7.</i>	<i>Timing echoes.</i>	<i>Mathematics- Algebra/ Computation. Skills: PD; MM.</i>
1.3	<i>represent transverse and longitudinal waves in displacement-position and displacement-time graphs.</i>	<i>Note: a progressive wave varies in both time and space simultaneously. To represent it on paper, either time or position must be held constant. Refer to SO D2.6.</i>	<i>Extract information about wave parameters from graphs representing waves.</i>	<i>Mathematics: Trigonometric functions. Skills: ORR; AI.</i>

2. SOUND

Production and Propagation

2.1	<i>describe how sound is produced and propagated in a medium;</i>	<i>Sound is transmitted as a longitudinal wave and is produced by vibrating systems.</i>	<i>Cup and string telephone. Different sounds produced by vibrating systems. For example, stretch rubber bands.</i>	<i>Biology – Hearing.</i>
2.2	<i>relate the terms 'pitch' and 'loudness' to wave parameters;</i>	<i>Pitch - frequency Loudness - amplitude. Recall the range of frequencies detectable by the normal human ear;</i>	<i>Playing drums and steel pan. Tuning forks. Using bottles with water at different heights.</i>	

Speed of Sound

2.3	<i>apply the speed of sound to practical situations;</i>	<i>Thunder and lighting and the proximity of the strike.</i>	<i>Estimate the speed of sound in air using echoes.</i>	<i>Skills: MM; ORR; AI; PD.</i>
-----	--	--	---	---------------------------------

SECTION C - WAVES AND OPTICS (cont'd)

SPECIFIC OBJECTIVES	CONTENT/ EXPLANATORY NOTES	SUGGESTED PRACTICAL ACTIVITIES	SKILLS AND INTER- RELATIONSHIP
Students should be able to:			
2.4 cite evidence that sound waves reflect, refract, diffract and interfere;	<p><i>Reflect – echoes</i></p> <p><i>Refract – sound travelling from air to water.</i></p> <p><i>Diffract – hearing sound around corners/barriers.</i></p> <p><i>Interfere – sound systems.</i></p>		
2.5 describe the use of ultrasound.	<p><i>Definition of ultrasound; pre-natal and materials testing.</i></p>		<i>Biology- Reproduction.</i>
3. ELECTROMAGNETIC WAVES			
3.1 state the properties of e.m. waves;	<p><i>For example, travels same speed, are transverse and propagates in a vacuum.</i></p>		
3.2 differentiate between types of e.m. waves in terms of their wavelengths;	<p><i>Radio, infrared, visible, ultraviolet, x-rays, Y-rays. Discuss the spectrum.</i></p>	<i>Research project.</i>	
3.3 identify a source and use of each type of e.m. wave.			<i>Biology – Medical applications of Y-rays and x- rays.</i>
4. LIGHT WAVES			
<u>Wave Particle Duality</u>			
4.1 compare the rival theories of light held by scientists;	<p><i>Theories of Huygens, Newton, Young, Einstein. Recall that in the twentieth century experiments have provided evidence that light has both a particle and a wave nature. Knowledge of the photo-electric effect not required. Photo sensors, digital cameras.</i></p>		

SECTION C - WAVES AND OPTICS (cont'd)

SPECIFIC OBJECTIVES	CONTENT/ EXPLANATORY NOTES	SUGGESTED PRACTICAL ACTIVITIES	SKILLS AND INTER- RELATIONSHIP
---------------------	----------------------------------	--------------------------------------	--------------------------------------

Students should be able to:

4.2	<i>conduct a Young's double slit experiment to show that light is a wave;</i>	<i>Diffraction and interference.</i>	Young's experiment looking at a straight filament lamp through a double slit. <i>Ripple tank.</i>
-----	---	--------------------------------------	--

Rays of Light

4.3	<i>explain why the diffraction of light is not normally observed;</i>	Wavelength comparable to the width of slit.	<i>Use ripple tank. Observe diffraction with gaps of different widths.</i>
4.4	<i>apply the principle that light travels in straight lines;</i>	<i>Use straight lines to represent beams. Shadows, eclipses, pin hole camera.</i>	<i>Demonstrate that light travels in straight lines. Construct a pin hole camera.</i> <i>Skill: MM.</i>

Reflection

4.5	<i>apply the laws of reflection;</i>		<i>Perform experiments to show the angle of incidence and the angle of reflection are equal.</i> <i>Skills: MM; ORR.</i>
4.6	describe the formation of images in a plane mirror;	Object and image distances are equal. The image is virtual and the object size is equal to the image size.	Locate virtual image using: (a) ray plotting; (b) no parallax method. Construct diagrams to show the formation of virtual images. <i>Mathematics- Transformations</i> <i>Skills: MM; ORR; PD.</i>

Refraction

4.7	give examples of observations which indicate that light can be refracted;	Appearance of water on the road, apparent depth of swimming pool. Refraction occurs as a result of the change of speed of light.	Activities to illustrate refraction of light, for example, pencil in water. <i>Skills: MM; ORR.</i>
-----	---	--	--

SECTION C - WAVES AND OPTICS (cont'd)

SPECIFIC OBJECTIVES	CONTENT/ EXPLANATORY NOTES	SUGGESTED PRACTICAL ACTIVITIES	SKILLS AND INTER- RELATIONSHIP
Students should be able to:			
4.8 describe the refraction of light rays;	Recall that the passage of a ray of light through a rectangular block may result in lateral displacement of that ray.	Passage of light rays through: (a) rectangular blocks; (b) triangular prisms. Draw diagrams.	<i>Skill: MM.</i>
4.9 describe how a prism may be used to produce a spectrum;	Use a source of white light. <i>Newton's experiment with prisms.</i>	Demonstrate: (a) dispersion using a triangular prism. (b) rainbow.	<i>Skill: MM.</i>
4.10 apply Snell's Law;	<i>Definition of refractive index.</i>	Perform an experiment to test Snell's Law.	<i>Mathematics-Trigonometry.</i> <i>Skills: MM; ORR; AI.</i>

Critical Angle and Total Internal Reflection

4.11 explain 'critical angle' and 'total internal reflection';		Measure critical angle in glass or other transparent material. Use diagrams to illustrate.	<i>Skills: MM; ORR.</i>
4.12 relate critical angles to total internal reflection;	<i>Definition of total internal reflection.</i>		<i>Mathematics-Trigonometry.</i> <i>Skill: AI.</i>
4.13 draw diagrams illustrating applications of total internal reflection.	Periscope, fibre optic cable, endoscopes.		

SECTION C - WAVES AND OPTICS (cont'd)

SPECIFIC OBJECTIVES	CONTENT/ EXPLANATORY NOTES	SUGGESTED PRACTICAL ACTIVITIES	SKILLS AND INTER- RELATIONSHIP
Students should be able to:			
5. LENSES			
<u>Action of Lenses</u>			
5.1 illustrate the effect of converging and diverging lenses on a beam of parallel rays;	<i>Use ray boxes or virtual simulation.</i>	Investigate the properties of converging and diverging lenses on a beam of parallel rays.	Biology – Eye. <i>Skills: MM; ORR.</i>
5.2 define <i>the terms</i> :			
(a) principal axis;			
(b) principal focus;			
(c) focal length;			
(d) focal plane;			
(e) magnification;			
<u>Image Formation</u>			
5.3 <i>differentiate</i> between real and virtual images;		<i>Perform experiments to locate real and virtual images and draw diagrams.</i>	<i>Skills: MM; ORR.</i>
5.4 <i>apply the equations for magnification</i> ;	<i>Magnification = $\frac{\text{image size}}{\text{object size}} = \frac{\text{image distance (v)}}{\text{object distance (u)}}$.</i>		<i>Biology – Drawing.</i> <i>Mathematics - Transformations,</i> <i>Skill: AI.</i>
5.5 <i>determine the focal length of a converging lens.</i>	<i>Use lens formula and scale diagram:</i> $\frac{1}{f} = \frac{1}{u} + \frac{1}{v}$	<i>Perform experiments to measure focal length of converging lens.</i>	<i>Mathematics - Functions and Relations; Algebra/ Computation.</i> <i>Skills: MM; ORR; AI; PD.</i>

SECTION C - WAVES AND OPTICS (cont'd)

Suggested Teaching and Learning Activities

To facilitate students' attainment of the objectives of this Section, teachers are advised to engage students in the teaching and learning activities below. These activities are designed to promote inquiry-based learning and cater to students with various learning styles.

1. **Standing waves:** Conduct experiments to explore why ants survive in an operating microwave oven.

2. **Light, refraction:** Discuss how raindrops and prisms have similar effect with light in forming rainbows and spectrum respectively using diagrams. Simulation at:

<http://micro.magnet.fsu.edu/optics/activities/students/prisms.html>

3. **Electromagnetic spectrum:** List a use of each band in the electromagnetic spectrum with examples and make a model to depict them as for a science centre display. Show time scales of the use/discovery of examples you show.

4. **Sound:** Arrange a field trip to a concert hall to look at its design and how this affects the acoustics. Students should write a report of the activity. Discuss the quality of a band concert in a hall versus being played in the open air.

<http://www.concerthalls.org/>

5. **Transverse and longitudinal waves; transmission of energy:** Show how earthquakes are located. How tsunami waves are formed and why are they so much larger than normal sea waves?

This video segment from Nature examines the anatomy of the tsunami and the possibility that animals sensed the coming waves of destruction.

<http://www.teachersdomain.org/resource/nat08.earth.geol.tec.waves/>

6. **Sound waves:** Imagine you are a bat looking in the darkness of the caves for your companions who have ventured deep into the caves but instead there is a large predator lurking. Write a short story of your adventure. Make sure you include the principles of Physics used in your story.

7. **Wave-particle duality:** Identify modern technology that operates on the principle that light behaves as a particle. Observe pictures with a digital camera and a traditional film camera and compare the differences between them including how each forms the image.

8. **Light, reflection, transmission:** Discuss the holographic projectors in "Star Trek". How realistic are they in producing holograms.

http://memory-alpha.org/wiki/Category:Holographic_technology.

◆ SECTION D - ELECTRICITY AND MAGNETISM

In this section, Electricity and Magnetism, we explore electrical, magnetic and electromagnetic principles and phenomena. The importance of electronics in modern society is also introduced.

GENERAL OBJECTIVES

On completion of this Section, students should:

1. *understand electrostatic phenomena;*
2. *understand the ways in which electricity is conducted;*
3. *understand electrical quantities and the relations between them;*
4. *have a working knowledge of electrical circuits and components;*
5. *be aware of the applications of electronics in technology;*
6. *understand the simple phenomena associated with magnets;*
7. *have a working knowledge of electromagnetic phenomena.*

SPECIFIC OBJECTIVES	CONTENT/ EXPLANATORY NOTES	SUGGESTED PRACTICAL ACTIVITIES	SKILLS AND INTER- RELATIONSHIP
Students should be able to:			
1. ELECTROSTATICS			
<u>Electric Charge, Q</u>			
1.1 <i>explain the charging of objects;</i>	<i>Explain in terms of properties of electrons which are relatively free to move; charging of glass, perspex or polythene by rubbing with a dry cloth and explain in terms of electron transfer by friction.</i>	Demonstrate 'charging by friction'.	
1.2 <i>describe the forces that electric charges exert on each other;</i>	<i>The forces between charges as a fundamental property of electric charges.</i>	<i>Perform simple activities to show that like charges repel and unlike charges attract.</i>	<i>Skills: MM; ORR.</i>
1.3 <i>explain charging by induction;</i>	<i>How a charged object can attract objects having zero net charge.</i>	<i>Perform simple experiment.</i>	

SECTION D - ELECTRICITY AND MAGNETISM (cont'd)

SPECIFIC OBJECTIVES	CONTENT/ EXPLANATORY NOTES	SUGGESTED PRACTICAL ACTIVITIES	SKILLS AND INTER- RELATIONSHIP
Students should be able to:			
<u>Electric Fields</u>			
1.4	<i>define an electric field;</i>	<i>Draw the electric fields around and between point charges, and between charged parallel plates; Refer to other force fields such as gravitational and magnetic. Refer to SO A3.2; D6.7.</i>	
1.5	<i>describe one hazard and one useful application of static charge.</i>	<i>Electrostatic painting; Lightning strikes, dust extraction, photocopying, static build up on vehicles. The effects of a local charged ionised atmosphere.</i>	
2. CURRENT ELECTRICITY			
2.1	<i>distinguish between conductors and insulators;</i>	<i>Definitions, properties and classification.</i>	<i>Use a low voltage test circuit with lamp indicator to test different materials.</i>
			<i>Chemistry - Electrons; properties of metals and non-metals.</i>
			<i>Skills: MM; ORR.</i>
2.2	<i>state that an electric current in a metal consists of a flow of electrons;</i>	<i>In other conducting media an electric current may consist of the movement of both negative and positive charge carriers.</i>	<i>Chemistry- Electrons; properties of metals and non-metals.</i>
		<i>For example, the use of silicon and germanium, in semi-conductors and electrolytes in batteries.</i>	

SECTION D - ELECTRICITY AND MAGNETISM (cont'd)

SPECIFIC OBJECTIVES	CONTENT/ EXPLANATORY NOTES	SUGGESTED PRACTICAL ACTIVITIES	SKILLS AND INTER- RELATIONSHIP
Students should be able to:			
2.3 differentiate between electron flow and conventional current;	<i>The convention behind current flow.</i>		
2.4 <i>state the unit of electrical current;</i>	<i>Ampere, A.</i>		
2.5 apply the relationship $Q = It$;	The unit of charge, the coulomb, can be obtained from this equation. Thus, 1 coulomb = 1 amp-second.		Chemistry-Electro-Chemistry. Mathematics-Algebra/ Computation. <i>Skill: AI.</i>
<u>Alternating Current</u>			
2.6 differentiate between direct and alternating currents;	Recognise that current reverses direction of flow in a.c. systems.	Draw current time or voltage time graphs to represent direct and alternating current <i>simulations.</i>	<i>Mathematics: Functions and Graphs.</i>
2.7 analyse current-time or voltage-time graphs.	<i>Use $f = 1/T$. Deduce the period and frequency of alternating currents or voltages. Refer to SO C1.2.</i>		<i>Mathematics-Algebra/ Computation. Skill: AI.</i>
3. ELECTRICAL QUANTITIES			
<u>Power, P and Energy, E</u>			
3.1 cite examples of the conversion of electrical energy to other forms and vice versa;	<i>Refer to SO A5.3.</i>	Demonstrate energy conversions in the laboratory.	

SECTION D - ELECTRICITY AND MAGNETISM (cont'd)

SPECIFIC OBJECTIVES	CONTENT/ EXPLANATORY NOTES	SUGGESTED PRACTICAL ACTIVITIES	SKILLS AND INTER- RELATIONSHIP
Students should be able to:			
3.2	<i>apply the relationship $V = E/Q$;</i>	<i>Definition of terms and their units.</i>	<i>Mathematics- Algebra/ Computation Skill: AI.</i>
3.3	<i>apply the relationship $P = IV$;</i>	<i>Compare consistency of units for $P=IV$ and $P= E/t$. Refer to SO A5.11.</i>	<i>Mathematics - Algebra/ Computation.</i>
3.4	<i>discuss the importance of conserving electrical energy and the means of doing so.</i>	<i>Limited reserves of fossil fuel hence the need to conserve. Fluorescent, LED rather than incandescent lamps. Solar rather than electrical or gas water heaters. High efficiency refrigeration and air condition units.</i>	<i>Chemistry - Burning of hydrocarbons. Biology-Ecology. Skill: AI.</i>
4.	CIRCUIT AND COMPONENTS		
<u>Circuit Diagrams</u>			
4.1	<i>use symbols to construct circuit diagrams;</i>	<i>Refer to list of Graphical Symbols.</i>	<i>Skill: MM.</i>
4.2	<i>differentiate between series and parallel circuits;</i>	<i>Consider series, parallel and series- parallel combinations and polarity of devices. Simple series circuits with diode, resistor and instruments</i>	<i>Set up a simple circuit given a circuit diagram paying due regard to the polarity and suitability of components.</i>

SECTION D - ELECTRICITY AND MAGNETISM (cont'd)

SPECIFIC OBJECTIVES	CONTENT/ EXPLANATORY NOTES	SUGGESTED PRACTICAL ACTIVITIES	SKILLS AND INTER- RELATIONSHIP	
Students should be able to:				
Cells				
4.3	<i>explain the functions of the various parts of a zinc-carbon cell;</i>	<i>The parts of the cell and their functions. Mention the fact that there are other types of primary cells.</i>	Draw a diagram.	Chemistry - Electro-chemistry.
4.4	<i>distinguish between primary and secondary cells;</i>	Comparison of characteristics such as: (a) terminal voltage; (b) maximum current; (c) internal resistance; (d) portability; (e) rechargeability.		
4.5	<i>draw a circuit diagram to show how a secondary cell can be recharged;</i>	Note polarity and charging voltage.		
I - V Relationships				
4.6	<i>investigate the relationship between current and potential difference;</i>	(a) <i>Metallic conductors at constant temperature.</i> (b) <i>Filament lamps.</i> (c) <i>Semiconductor diodes.</i> (d) <i>Solutions of copper sulphate in water using copper electrodes.</i>	Perform these experiments. Draw I – V graphs from the result of such experiments and draw appropriate conclusions from the graphs obtained.	Chemistry- Properties of matter. Mathematics- Functions, Relations and Graphs. <i>Skills: MM; ORR; AI; PD.</i>
<i>Refer to SO A1.4.</i>				

SECTION D - ELECTRICITY AND MAGNETISM (cont'd)

SPECIFIC OBJECTIVES	CONTENT/ EXPLANATORY NOTES	SUGGESTED PRACTICAL ACTIVITIES	SKILLS AND INTER- RELATIONSHIP
Students should be able to:			
<u>Resistance, R</u>			
4.7 explain the concept of resistance;	<i>Point out the fact that resistance varies with the current in some cases.</i>		
4.8 apply the relationship $R = \frac{V}{I}$;	<i>Ohm's Law. Refer to SO D4.6.</i>	<i>Determine resistance using the formula $R = \frac{V}{I}$.</i>	<i>Mathematics- Algebra/ Computation. Skill: AI.</i>
4.9 explain why it is necessary for an ammeter to have a very low resistance;			
4.10 explain why it is necessary for a voltmeter to have a very high resistance;			
4.11 <i>solve problems involving series and parallel resistance;</i>	<i>Use the formulae: $R_s = R_1 + R_2 + R_3 \dots$ for resistors in series; and $\frac{1}{R_p} = \frac{1}{R_1} + \frac{1}{R_2} + \frac{1}{R_3} + \dots$ for resistors in parallel;</i>		<i>Mathematics- Algebra/ Computation. Skill: AI.</i>

SECTION D - ELECTRICITY AND MAGNETISM (cont'd)

SPECIFIC OBJECTIVES	CONTENT/ EXPLANATORY NOTES	SUGGESTED PRACTICAL ACTIVITIES	SKILLS AND INTER- RELATIONSHIP
Students should be able to:			
4.12 <i>solve problems involving series, parallel and series-parallel circuits;</i>	Properties of current and potential difference (p.d.) in series and parallel circuits.	<p>Set up a series circuit and measure current at various points.</p> <p><i>Set up a parallel circuit and measure current in the branches and on entry and exit.</i></p> <p><i>Set up a series circuit and measure p.d. across components.</i></p> <p><i>Set up a parallel circuit and measure p.d. across components.</i></p>	<p><i>Mathematics.</i></p> <p><i>Skills: MM; ORR; AI; PD.</i></p>

Electricity in the Home

4.13 discuss the reasons for using parallel connections of domestic appliances;			
4.14 explain the purpose of a fuse or circuit breaker and the earth wire;	<i>Highlight safety issues. Include fuse in live wire.</i>		
4.15 select a fuse or circuit breaker of suitable current rating for a given appliance;			
4.16 state the adverse effects of connecting electrical appliances to incorrect or fluctuating voltage supplies.			

SECTION D - ELECTRICITY AND MAGNETISM (cont'd)

SPECIFIC OBJECTIVES	CONTENT/ EXPLANATORY NOTES	SUGGESTED PRACTICAL ACTIVITIES	SKILLS AND INTER- RELATIONSHIP
---------------------	----------------------------------	--------------------------------------	--------------------------------------

Students should be able to:

5. ELECTRONICS

Students should be able to:

5.1	describe how a semi-conductor diode can be used in half wave rectification;	<i>Sketch V-t graphs to compare variation of voltage with time before or after rectification.</i>	<i>Mathematics- Functions, Relations and Graphs.</i>
5.2	<i>differentiate between direct current from batteries and rectified alternating current by a consideration of the V – t graphs for both cases;</i>		

Logic Gates

5.3	<i>recall the symbols for AND, OR, NOT, NAND, NOR logic gates;</i>	Limited to two-input logic gates.	
5.4	<i>state the function of each gate with the aid of truth tables;</i>	<i>Refer to SO D1.3 for similarity to electrical charges.</i>	
5.5	<i>analyze circuits involving the combinations of not more than three logic gates;</i>	<i>Example: simple alarm circuits.</i>	
5.6	<i>discuss the impact of electronic and technological advances on society.</i>		

SECTION D - ELECTRICITY AND MAGNETISM (cont'd)

SPECIFIC OBJECTIVES	CONTENT/ EXPLANATORY NOTES	SUGGESTED PRACTICAL ACTIVITIES	SKILLS AND INTER- RELATIONSHIP
---------------------	----------------------------------	--------------------------------------	--------------------------------------

Students should be able to:

6. **MAGNETISM**

Permanent Magnets

6.1 <i>differentiate between magnetic and non-magnetic materials;</i>			
6.2 <i>explain how a magnet can attract an unmagnetised object;</i>	<i>Refer to SO D1.3 for similarity to electrical charges.</i>		
6.3 <i>distinguish between materials used to make "permanent" and "temporary" magnets;</i>	<i>Permanent magnets: steel and magnadur. Temporary magnets: iron and mumetal.</i>		
6.4 <i>identify the poles of a magnetic dipole;</i>	<i>Alignment with the earth's magnetic field.</i>	Perform an activity to identify the poles of a magnetic dipole.	<i>Skill: MM.</i>

Magnetic Forces

6.5 <i>investigate the forces between magnetic poles;</i>	The effect of the polarity and separation of magnets on the magnitude of the force between them.	<i>Use two strong magnets to investigate forces between like and unlike poles.</i>	
6.6 <i>define a magnetic field;</i>	A magnetic field line indicates the direction of the magnetic force acting on an N-pole;		

SECTION D - ELECTRICITY AND MAGNETISM (cont'd)

SPECIFIC OBJECTIVES	CONTENT/ EXPLANATORY NOTES	SUGGESTED PRACTICAL ACTIVITIES	SKILLS AND INTER- RELATIONSHIP
Students should be able to:			
6.7 map magnetic fields.	Familiarity with iron filings and plotting compass methods: <i>(a) around a single strong magnet.</i> <i>(b) around and between two strong magnets.</i> <i>Oriented parallel and anti-parallel and pole to pole with each other.</i>	Map the magnetic field using iron filings and plotting compass.	<i>Skill: MM.</i>
7. ELECTROMAGNETISM			
7.1 conduct simple experiments to investigate the magnetic field pattern around current-carrying conductors;	Straight conductors, flat coils, solenoids.	Map the fields for the given conductor. Sketch the magnetic flux patterns.	<i>Skills: MM; ORR.</i>
7.2 apply suitable rules which relate the direction of current flow to the direction of the magnetic field;	<i>Right hand grip rule, right hand screw rule.</i>		
7.3 describe a commercial application of an electromagnet;	Example: Starter Motor. Magnetic Relay.	Construct a simple electromagnet.	<i>Skills: MM.</i>
<u>Electromagnetic Force</u>			
7.4 conduct an experiment which demonstrates the existence of a force on a current-carrying conductor placed in a magnetic field;		Demonstrate the force on the current carrying conductor in a magnetic field.	

SECTION D - ELECTRICITY AND MAGNETISM (cont'd)

SPECIFIC OBJECTIVES	CONTENT/ EXPLANATORY NOTES	SUGGESTED PRACTICAL ACTIVITIES	SKILLS AND INTER- RELATIONSHIP
Students should be able to:			
7.5 sketch the resultant magnetic flux pattern when a current carrying wire is placed perpendicular to a uniform magnetic field;			Skill: ORR.
7.6 apply Fleming's left-hand (motor) rule;	<i>Predict what will happen when current flow perpendicular to a uniform magnetic field. Refer to SO E3.5.</i>		
7.7 identify the factors that affect the force on a current-carrying conductor in a magnetic field;	<i>Strength of the field and on the magnitude of the current.</i>		
<u>Motors</u>			
7.8 explain the action of a D.C. motor;		Draw a diagram of a simple D.C. electric motor. <i>Appliances such as fans, mixers.</i>	
<u>Induced e.m.f.</u>			
7.9 describe simple activities which demonstrate an induced e.m.f.;	Coil and magnets; two coils.	<i>Perform activities demonstrating induced e.m.f.</i>	<i>Skill: MM.</i>
7.10 conduct simple experiments to show the magnitude of the induced e.m.f.;	<i>Effect of the rate of change of magnetic flux experienced by the conductor.</i>	Perform experiments to investigate the factors which affect the magnitude of the induced e.m.f.	<i>Skills: MM; ORR; AI; PD.</i>

SECTION D - ELECTRICITY AND MAGNETISM (cont'd)

SPECIFIC OBJECTIVES	CONTENT/ EXPLANATORY NOTES	SUGGESTED PRACTICAL ACTIVITIES	SKILLS AND INTER- RELATIONSHIP
Students should be able to:			
7.11 <i>predict the direction of induced current given the direction of motion of the conductor and that of the magnetic field;</i>			
7.12 <i>explain the action of the A.C. generator;</i>		<i>Sketch graphs to represent the output from a simple A.C generator.</i>	<i>Mathematics – Graphs and Trigonometric functions. Skill: ORR.</i>
<u>Transformers</u>			
7.13 <i>explain the principle of operation of a transformer;</i>	Diagram of a simple transformer.	Construct a simple transformer.	<i>Skill: MM.</i>
7.14 <i>state the advantages of using a.c. for transferring electrical energy;</i>			
7.15 <i>apply the ideal transformer formula</i> $P_{out} = P_{in}$.	Transformer formulae to solve problems $\frac{V_s}{V_p} = \frac{N_s}{N_p} = \frac{I_p}{I_s}$	Perform activities to show that for an ideal transformer $\frac{V_s}{V_p} = \frac{N_s}{N_p} = \frac{I_p}{I_s}$	<i>Mathematics- Algebra/ Computation</i>

SECTION D - ELECTRICITY AND MAGNETISM (cont'd)

Suggested Teaching and Learning Activities

To facilitate students' attainment of the objectives of this Section, teachers are advised to engage students in the teaching and learning activities below. These activities are designed to promote inquiry-based learning and cater to students with various learning styles.

1. **Earth's magnetic poles:** Write a science fiction on a trip to the centre of Earth and use it to explain how planet Earth gets its magnetism.

<http://www.physics.org/article-questions.asp?id=64>

2. **Magnetic fields:** Prepare a five-minute presentation on how frogs, and by extension humans can be levitated.

<http://www.physics.org/facts/frog-really.asp>

3. **Electromagnetic induction:** Design a poster to show how metal detectors work employing the principles of electromagnetic induction. Simulation at

<http://micro.magnet.fsu.edu/electromag/java/detector/index.html>

4. **Electric fields:** Prepare a safety brochure on the dangers of lightning. Include and explain how tingling of the skin and hair raising can be indicators. During thunderstorms, time the difference between seeing the lightning and hearing the thunder to determine how far away the storm is.

<http://theboar.org/science/2010/nov/7/hair-raising-truth-about-lightning/>

Simulation - <http://micro.magnet.fsu.edu/electromag/java/lightning/index.html>

5. **Static electricity:** Prepare a poster showing examples of use of static electricity in life.

<http://hubpages.com/hub/Uses-of-Static-Electricity>

6. **Magnetic and true north:** Fieldwork – determine the difference in the true north found by astronomical position of the north star and the magnetic north using a compass. Observe over a few weeks and see if there are any differences. Write a report.

<http://adventure.howstuffworks.com/survival/wilderness/true-north.htm>

Simulation: <http://micro.magnet.fsu.edu/electromag/java/compass/index.html>

7. **Electromagnetism:** As a class project, build an electromagnet and experiment with their operations.

<http://education.jlab.org/beamsactivity/6thgrade/magnetsandelectromagnets/overview.html>

8. **Transformers:** make a list of the items in the home that require a transformer when plugged in. Explain why this is so.

SECTION D - ELECTRICITY AND MAGNETISM (cont'd)

9. **AC and DC:** Write an essay on how Direct Current (DC) and Alternating Current(AC) were discovered. Why did the AC prevail? List items in the house that use AC and those that use DC.

<http://www.teachersdomain.org/resource/phy03.sci.phys.mfw.acdc/>

10. **Ohm's law:** observe the simulation at:

<http://micro.magnet.fsu.edu/electromag/java/ohmslaw/index.html>

◆ SECTION E - THE PHYSICS OF THE ATOM

This is the branch of physics that studies the structure of the atom and the interaction of the sub-atomic particles of matter and electromagnetic fields. Students will appreciate how energy can be released from inside the atom and become aware of its impact on society and the environment.

GENERAL OBJECTIVES

On completion of this Section, students should:

1. *appreciate the development of atomic theory and the concept of the nucleus;*
2. *understand how the elements differ in atomic structure;*
3. *be familiar with the phenomenon of radioactivity and the safety measures when dealing with radioactive substances;*
4. *know that a change in the nuclear mass is associated with the release of energy;*
5. *appreciate the importance of nuclear energy on society and the environment.*

SPECIFIC OBJECTIVES	CONTENT/ EXPLANATORY NOTES	SUGGESTED PRACTICAL ACTIVITIES	SKILLS AND INTER- RELATIONSHIP
---------------------	----------------------------------	--------------------------------------	--------------------------------------

Students should be able to:

1. MODELS OF THE ATOM

1.1	describe the work done in establishing the modern view of the atom;	Include Thomson, Rutherford, Bohr, Chadwick.	<i>Chemistry - Atoms and the Periodic table.</i>
1.2	<i>describe the Geiger-Marsden experiment.</i>	Establish the nuclear structure of the atom. Consider that the nucleus contains protons and neutrons of approximately equal mass.	<i>Chemistry- Structure of the atom.</i>

2. STRUCTURE OF THE ATOM

Particles in the Atom

2.1	<i>sketch the structure of simple atoms;</i>	Include the distribution of charge.	Chemistry- Structure of the atom, metallic bonding.
-----	--	-------------------------------------	---

SECTION E - THE PHYSICS OF THE ATOM (cont'd)

SPECIFIC OBJECTIVES	CONTENT/ EXPLANATORY NOTES	SUGGESTED PRACTICAL ACTIVITIES	SKILLS AND INTER- RELATIONSHIP
Students should be able to:			
2.2	compare the mass and charge of the electron with the mass and charge of the proton;	Mention could be made of the absolute values in kg and C.	
2.3	explain why an atom is normally neutral and stable;		<i>Chemistry- Structure of the atom.</i>
2.4	<i>apply the relationship</i> $A = Z + N$;	Use of standard notation for representing a nuclide, A_ZX for example ${}^{12}_6C$.	Chemistry - Atomic number and atomic mass.
2.5	explain what is meant by the term "isotope";		Chemistry- Isotopes.
2.6	relate the shell model of the atom to the periodic table.	Any element in the periodic table has one more proton than an element before it.	Chemistry- Periodic table.

3. RADIOACTIVITY

Radioactive Emissions

3.1	describe Marie Curie's work in the field of radioactivity;		<i>Research biography.</i>	<i>Chemistry - Marie Curie</i>
3.2	<i>state the nature of the three types of radioactive emissions;</i>	Relationship between radioactivity and nuclear instability.	Video simulation.	
3.3	describe experiments to compare the ranges of α , β , and γ emission;			
3.4	describe the appearance of the tracks of radioactive emissions in a cloud chamber;	The details of the operation of the cloud chamber are not required.		

SECTION E - THE PHYSICS OF THE ATOM (cont'd)

SPECIFIC OBJECTIVES	CONTENT/ EXPLANATORY NOTES	SUGGESTED PRACTICAL ACTIVITIES	SKILLS AND INTER- RELATIONSHIP
Students should be able to:			
3.5	predict the effects of magnetic and electric fields on the motion of α and β particles and γ rays;	Refer to S.O.D7.7.	
3.6	<i>interpret nuclear reactions in the standard form;</i>	${}_{88}^{226}\text{Ra} \rightarrow {}_{86}^{222}\text{Rn} + {}_2^4\text{He}$ ${}_{6}^{14}\text{C} \rightarrow {}_{7}^{14}\text{N} + {}_{-1}^0\text{e}$	<i>Chemistry- Balancing equations.</i>
3.7	conduct an activity to demonstrate the random nature of radioactive decay;	<i>Activity from which a radioactive decay curve can be obtained.</i>	<i>Perform analogue demonstrations to illustrate random processes, for example, throwing of dice, tossing of coins.</i>
3.8	recall that the decay process is independent of the conditions external to the nucleus;		<i>Skills: MM; ORR; AI.</i>
<u>Half-life</u>			
3.9	use graphs of random decay to show that such processes have constant half-lives;	<i>Definition of the term "half-life", $T_{1/2}$. Use more than one set of values from graph for comparison.</i>	<i>Plot graphs of demonstrations performed in SO 3.7.</i>
			<i>Mathematics- Functions, Relations and Graphs.</i>
			<i>Skills: AI; ORR.</i>
3.10	<i>solve problems involving half-life;</i>		<i>Mathematics- Algebra/ Computation.</i>
<u>Radioisotopes</u>			
3.11	discuss the useful applications of radioisotopes;	<i>Tracers. Medical and industrial applications. Carbon dating.</i>	<i>Chemistry- Isotopes.</i>

SECTION E - THE PHYSICS OF THE ATOM (cont'd)

SPECIFIC OBJECTIVES	CONTENT/ EXPLANATORY NOTES	SUGGESTED PRACTICAL ACTIVITIES	SKILLS AND INTER- RELATIONSHIP
Students should be able to:			
<u>Nuclear Energy</u>			
3.12	relate the release of energy in a nuclear reaction to a change in mass;	Application of Einstein's equation: $\Delta E = \Delta mc^2$. Include fission and fusion.	Mathematics- Algebra/ Computation. Skill: AI.
3.13	cite arguments for and against the utilisation of nuclear energy.	Cost of environmental impact; disposal; safety.	Biology-Ecology.

Suggested Teaching and Learning Activities

To facilitate students' attainment of the objectives of this Section, teachers are advised to engage students in the teaching and learning activities below. These activities are designed to promote inquiry-based learning and cater to students with various learning styles.

- Fusion and fission:** Write a play of the story of "Cold Fusion" and its discovery. At the end of the play, explain how energy from fusion can only occur naturally in the sun.
<http://w3.gre.ac.uk/~bj61/talessi/tlr22.html>
- Nuclear Radiation:** Organise a class debate for and against the establishment of a nuclear reactor in the Caribbean.
<http://news.discovery.com/tech/top-five-nuclear-disasters.html>
<http://www.benefitsofnuclearpower.com/>
- Cosmic radiation:** Write a short science fiction story of an Astronomer travelling to Mars and the risks he or she is exposed to.
<http://spaceinfo.com.au/2011/05/07/space-travel-could-kill-you/>
- Nuclear radiation:** Design a poster showing the uses of radiation in medicine.
<http://health.howstuffworks.com/medicine/modern/nuclear-medicine.htm>
- Marie Curie:** Design a poster highlighting the accomplishments of Marie Curie particularly as a woman in a male dominated field.
http://nobelprize.org/nobel_prizes/physics/laureates/1903/marie-curie-bio.html
- Science in research:** Conduct research to ascertain if there are any scientists in the region working on nuclear energy. What are the challenges and opportunities for it in the region?

◆ GUIDELINES FOR THE SCHOOL-BASED ASSESSMENT

RATIONALE

School-Based Assessment (SBA) is an integral part of student assessment in the course covered by this syllabus. It is intended to assist students in acquiring certain knowledge, skills and attitudes that are critical to the subject. The activities for the School-Based Assessment are linked to the “Suggested Practical Activities” and should form part of the learning activities to enable the student to achieve the objectives of the syllabus.

During the course of study of the subject, students obtain marks for the competencies they develop and demonstrate in undertaking their SBA assignments. These marks contribute to the final marks and grades that are awarded to students for their performance in the examination.

The guidelines provided in this syllabus for selecting appropriate tasks are intended to assist teachers and students in selecting assignments that are valid for the purpose of the SBA. These guidelines are also intended to assist teachers in awarding marks according to the degree of achievement in the SBA component of the course. In order to ensure that the scores awarded by teachers are not out of line with the CXC standards, the Council undertakes the moderation of a sample of SBA assignments marked by each teacher.

School-Based Assessment provides an opportunity to individualise a part of the curriculum to meet the needs of students. It facilitates feedback to the students at various stages of the experience. This helps to build the self-confidence of the students as they proceed with their studies. School-Based Assessment further facilitates the development of critical skills and that allows the students to function more effectively in their chosen vocation and in everyday life. School-Based Assessment therefore, makes a significant and unique contribution to the development of relevant skills by the students. It also provides an instrument for testing them and rewarding them for their achievements.

PROCEDURES FOR CONDUCTING SBA

SBA assessments should be made in the context of normal practical coursework exercises. *It is expected that the exercises would provide authentic learning experiences.* Assessments should only be made after candidates have been taught the skills and given enough opportunity to develop them. **Sixteen** practicals over the two-year period would be considered the **minimum** number for candidates to develop their skills and on which to base realistic assessments. **These practicals MUST include all of the following:**

1. *Pendulum.*
2. *Momentum/Conservation of Energy.*
3. *Specific heat capacity/Specific Latent heat capacity.*
4. *Refraction.*
5. *Series and Parallel Circuits.*
6. *I-V Relationships.*
7. *Radioactivity Decay (Simulation).*

Each skill must be assessed at least three times over the two-year period. Candidates should be encouraged to do corrections so that misconceptions will not persist. As the assessment of certain skills, especially those requiring on-the-spot observation or involve looking at several

behaviours or criteria, teachers are advised to select not more than two skills to be assessed in any activity. The practical exercises selected to be used for assessment should make adequate demands on the candidates and the skills assessed should be appropriate for the exercises done. For the assessment of written work, the practical selected should be one that can be completed in the time allotted for the class and **the notebooks should be collected at the end of the period.**

Candidates who have not been assessed over the two-year period will be deemed absent from the whole examination. Under special circumstances, candidates who have not been assessed at all points may, at the discretion of CXC, have their marks pro-rated (adjusted proportionately).

1. In preparation for an SBA practical, the teacher should:

- (a) select tasks which must include the **seven (7)** topics on page 53 and should be related to a given syllabus objective. These tasks may be chosen from the “Suggested Practical Activities” and should fit in with the normal work being done in that class;
- (b) list the materials including quantities and equipment that will be needed for each student;
- (c) carry out the experiment beforehand, if possible, to ascertain the suitability of materials and the kind of results (observations, readings) which will be obtained, noting especially any unusual or unexpected results;
- (d) list the steps which will be required by the candidates in performing the experiment. From this it will be clear to the teacher how the candidates should be arranged in the laboratory, whether any sharing of equipment or materials is necessary, the skills which can be assessed from the practical, and the instructions to be given;
- (e) list the skills that may be assessed (for example, observation/recording/reporting, analysis and interpretation). **No more than two practical skills should be assessed from any one activity;**
- (f) select the skills to be assessed on this occasion. Skills other than those required for that year should also be included for teaching purposes;
- (g) work out the criteria for assessing each skill. This will form the basis of a mark scheme and a checklist.

2. The teacher should carry out the assessment and record the marks.

This is the most critical step in the assessment process. For a teacher to produce marks that are reliable, the marking must be consistent for all candidates and the marks should reflect the standard of performance at the level. The teacher must be able to justify the marks, and this occurs when there is a fixed set of conditions, factors or criteria for which the teacher looks. Marks should be submitted electronically to CXC on the SBA form provided. *The forms should be dispatched through the Local Registrar by the Moderator to reach CXC by 30 April of the year of the examination.*

ASSESSMENT OF PRACTICAL SKILLS

School-Based Assessment will assess skills under the profiles Experimental Skills and Use of Knowledge (Analysis and Interpretation only).

The assessment will be conducted during Terms 1 - 5 of the two-year period following the programme indicated in the Table below.

SBA SKILLS TO BE ASSESSED FOR CXC MODERATION

PROFILE	SKILLS	YEAR 1		YEAR 2		TOTAL		
		NO. OF TIMES SKILLS TO BE ASSESSED	MARKS	NO. OF TIMES SKILLS TO BE ASSESSED	MARKS	NO. OF TIMES SKILLS TO BE ASSESSED	MARKS	
XS	Manipulation/ Measurement	1	10	2	20	3	30	90 (30*)
	Observation/ Recording/ Reporting	1	10	2	20	3	30	
	Planning and Designing	2	20	1	10	3	30	
UK	Analysis and Interpretation	2	20	1	20	3	40	40 (10*)
	TOTAL	6	60	6	70	12	130	40*

***Weighted mark**

Investigative project to be done in Year 2.

The investigative project would be assessed for two skills, Planning and Design and Analysis and Interpretation.

Students who are pursuing two or more of the single science subjects (Biology, Chemistry, Physics) may opt to carry out ONE investigation* only from any of these subjects. [ONLY the marks for the investigation can be transferred across subjects.]

ASSESSMENT OF INVESTIGATION SKILLS

Proposal (Planning and Design)

The maximum marks available for the Proposal is **10 marks**

The format for this part is shown below

Observation/Problem/Research question stated	
Hypothesis	2 marks
Aim	1 mark
Materials and Apparatus	1 mark
Method	2 marks
<i>Controlled variables</i>	1 mark
<i>Expected Results</i>	2 marks
<i>Assumptions, Precautions/ Limitations</i>	1 mark

TOTAL **10 marks**

Implementation (Analysis and Interpretation)

The maximum marks available for the Implementation is **20 marks**

The format for this part is shown below:

Method	1 mark
Results	4 marks
Discussion	5 marks
Limitation	3 marks
Reflection	5 marks
<i>Conclusion</i>	2 marks

TOTAL **20 marks**

REPORTING FORMAT OF INVESTIGATION

PART A THE PROPOSAL (Planning and Design)

Statement of the Problem – Can be an observation, a problem

Hypothesis

Aim – Should be related to the hypothesis

Materials and Apparatus

Method – Should also include variables

Assumptions/Precautions

Expected Results

PART B THE IMPLEMENTATION (Analysis and Interpretation)

Method - Linked to Part A (change of tense)

Results

Discussion – Explanations/Interpretations/Trends

Limitations

Reflections

Conclusion

CRITERIA FOR ASSESSING INVESTIGATIVE SKILLS

A. PLANNING AND DESIGN

HYPOTHESIS		2
- Clearly stated	1	
- Testable	1	
AIM		1
- Related to hypothesis	1	
MATERIALS AND APPARATUS		1
- Appropriate materials and apparatus	1	
METHOD		2
- Suitable	1	
- At least one manipulated or responding variable	1	
CONTROLLED VARIABLE		1
-Controlled variable stated	1	
EXPECTED RESULTS		2
- Reasonable	1	
- Link with method	1	
ASSUMPTIONS/PRECAUTIONS/POSSIBLE SOURCES OF ERRORS		1
- Any one stated	1	
TOTAL		(10)

B. ANALYSIS AND INTERPRETATION

METHOD		1
Linked to Proposal, Change of tense		
RESULTS		4
- <i>Correct formulae and equations:</i>	2	
<i>Accurate (2)</i>		
<i>Acceptable (1)</i>		
- <i>Accuracy of data:</i>	2	
<i>Accurate (2)</i>		
<i>Acceptable (1)</i>		
DISCUSSION		5
- <i>Explanation</i>	2	
<i>Development of points:</i>		
<i>Thorough (2)</i>		
<i>Partial (1)</i>		
- <i>Interpretation</i>	2	
<i>Fully supported by data (2)</i>		
<i>Partially supported by data (1)</i>		
- <i>Trends:</i>	1	
<i>Stated</i>		
LIMITATIONS		3
-Sources of error identified	1	
-Precautions stated	1	
-Limitation stated	1	
REFLECTIONS		5
- <i>Relevance between the experiment and real life</i>	1	
<i>(Self, Society or Environment)</i>		
- <i>Impact of knowledge gain from experiment on self</i>	1	
- <i>Justification for any adjustment made during experiment</i>	1	
- <i>Communication of information</i>	2	
(Use of appropriate scientific language, grammar and clarity of expression all of the time (2); some of the time (1))		
CONCLUSION		2
- <i>Stated</i>	1	
- <i>Related to the aim</i>	1	
TOTAL		(20)

EXEMPLAR OF INVESTIGATIVE PRACTICAL

EXEMPLAR 1

PART A-THE PROPOSAL

Observation

During lunch break at school Darren noticed his rubber ball did not bounce as high as it normally would when it landed on a paper towel. Darren now claims if more paper towels are added the ball's rebound height would decrease.

Hypothesis: The height of rebound of a rubber ball decreases with the addition of paper towels.

Aim: To investigate the height of rebound [H_r] of a rubber ball with increasing paper towels.

Apparatus: Meter rule; paper towels; rubber ball; pencil.

Diagram

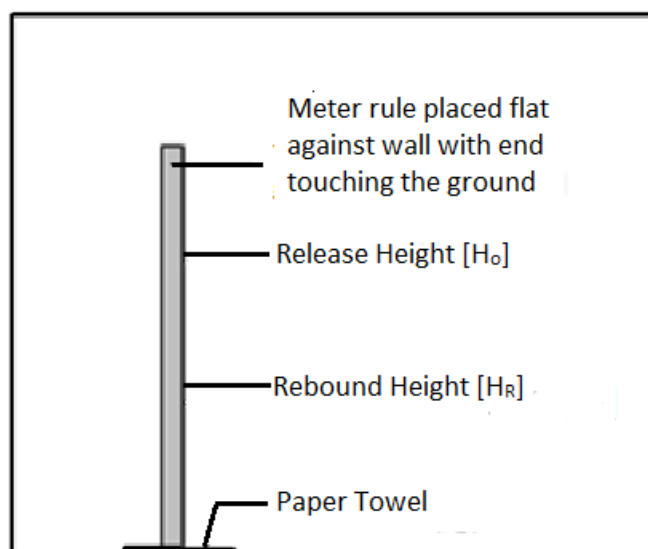

Variables

Independent – Number of paper towels

Dependent – Height of rebound

Controlled/ Constant – Rubber Ball; Height of Release

Method

1. Securely place meter rule vertically against a wall.
2. Mark off a suitable release height [H_o], [the ball must be allowed to FALL vertically and REBOUND on nearly the same straight line].
3. With no paper towels at the base of the meter ruler, release the rubber ball from the marked height [the ball must be completely above the marked line with its bottom edge just touching the line].
4. Observe and record the rebound height of the ball [H_R], [this should be done from in front of the ruler and eye level]. Repeat twice for this number of paper towels. Record all data.
5. Place a single paper towel at the base of the ruler and release it from marked height.
6. Observe and record the rebound height of the ball. Repeat steps 4 and 5 twice for that number of paper towels, recording all data.
7. Continue adding paper towels and repeat step 6 until there are 8 paper towels.
8. Calculate average rebound height [H_r] for each number of paper towels.
9. Plot a graph of Rebound Height [y axis] against Number of paper towels [x axis]

Expected Results

The rubber ball will reach maximum rebound height when it bounces on the ground with no paper towels present. As the paper towels are added it will rebound to a consistently lower height.

PART B- THE IMPLEMENTATION

Method

1. The meter rule was securely placed vertically against a wall with the 0 cm end touching the ground.
2. The release height, H_o , was set at 60 cm.
3. With no paper towels at the base of the meter ruler, the rubber ball was released from the 60 cm mark and the height of rebound was recorded. This step was repeated two more times and the data recorded.
4. A single paper towel was placed at the base of the ruler and the ball was released from the 60 cm mark. The new height of rebound was recorded. This was repeated two more times and data recorded.
5. Another paper towel was added and the rubber ball was released three times from the 60 cm mark. All rebound heights were recorded.
6. Step 5 was repeated until there were 7 paper towels at the base of the ruler.
7. The average rebound height [H_r] was calculated for each number of paper towels.
8. A graph of Rebound Height [y axis] against Number of paper towels [x axis] was plotted.

Results

# of paper towels	Rebound Height, H_r [cm] (Attempts)			Average Rebound Height, H_r [cm]
	1	2	3	
0	42	43	42	42
1	42	42	42	42
2	41	41	41	41
3	39	40	39	39
4	36	35	36	36
5	34	35	35	35
6	33	33	33	33
7	32	32	32	32

Graph of Rebound Height Against Number of Paper Towels for a Rubber Ball

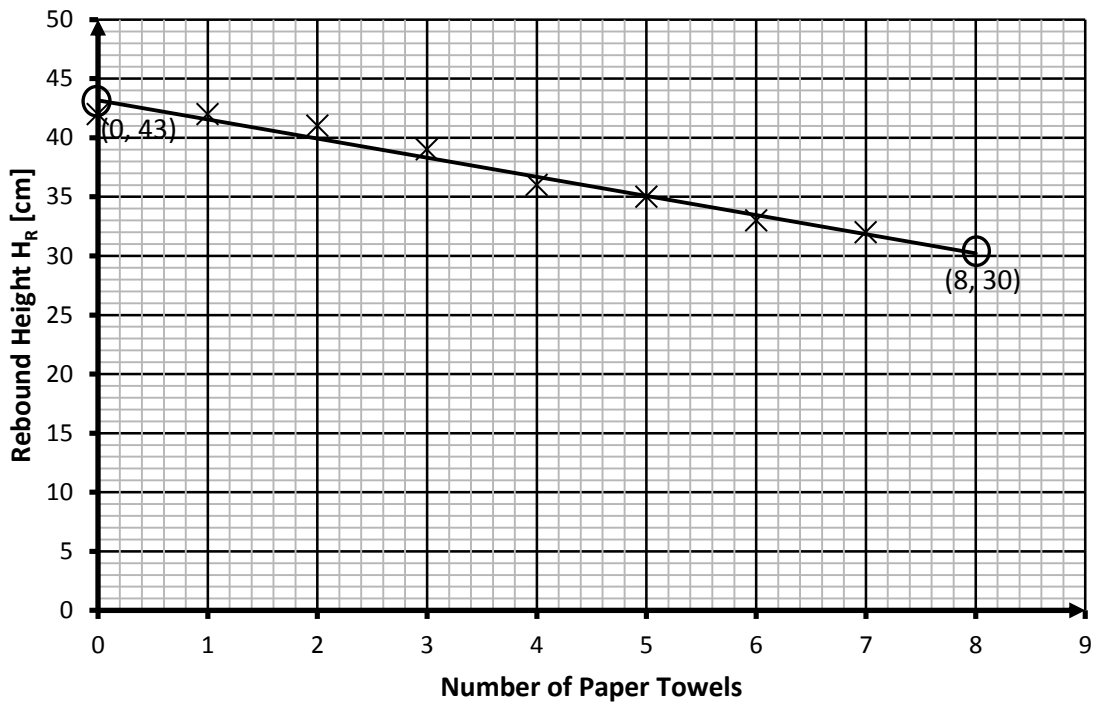

Calculations

Using points (0, 43) and (8, 30) to calculate the slope/gradient:

$$\begin{aligned} s &= \frac{y_2 - y_1}{x_2 - x_1} \\ &= \frac{43 - 30}{0 - 8} \\ &= \frac{13}{-8} \\ &= -1.6 \text{ (cm/paper towel)} \end{aligned}$$

Discussion

When the results were represented on a graph, the points defined a straight line. This allows the relation between the rebound height and the paper towels to be described by a linear equation of the form:

$$y = mx + c$$

Where y = Rebound height, x = number of paper towels, m = slope/gradient and c = intercept on the y -axis.

From the calculations the relation between the paper towels and the rebound height of the ball is described by:

$$R_H = -1.6N + 43$$

Where R_H is the rebound height and N is the number of paper towels.

When $N = 0$, the rebound height is 43 cm. As N increases, R_H decreases because the slope is negative. According to the relation, the rebound height will be zero when the number of paper towels is approximately 27.

Limitations

Sources of Error/Limitation

The ball achieves its rebound height for a very short time. To measure this height during this short time was difficult. At times only an approximation can be made. This introduces an error and a limitation in determining the accurate rebound height whenever a paper towel is added.

Precautions

Read rebound heights perpendicular to the ruler.
Repeat the experiment for each number of paper towels at least 3.

Reflections

The paper towels used in this experiment are much softer than the ground and the ball. This indicates that the paper towels decreases the rate of change of momentum of the ball and as a result decreases the force of impact of the ball with the ground. The reduction in the force of impact is as a result of the work done in compressing the paper towels on impact. Thus, the ball has less energy to rebound and as a result its rebound height decreases.

Conclusion

The rebound height decreases with increasing number of paper towels.

Exemplar 2

PART A - THE PROPOSAL

Observation

During a power outage one night, Devon lit a candle and without thinking, placed it near to his bedroom wall. Shortly after, the power was restored. He was surprised when he noticed the wall was warm. The following day in school he told some classmates about this and they decided to see how much energy a candle could release in a few minutes.

Aim: To investigate the heat energy released by a candle in 5 minutes.

Apparatus: Tripod stand; candle; insulated beaker; stirrer; thermometer; retort stand.

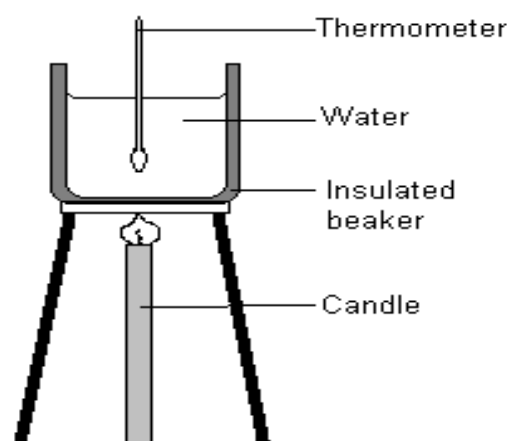

Variables

Independent – Time for which candle is lit

Dependent – Energy Released

Controlled – volume of water

Method

1. Fill the beaker up to the 300 ml mark with distilled water and place it on the tripod stand.
2. Using the retort stand, suspend the thermometer in the centre of the beaker [ensure the thermometer does not touch the bottom of the beaker]. Observe and record initial temperature of the water.
3. Place candle directly under the tripod stand and light it [ensure the flame is as close to the bottom of the beaker as possible].
4. Let the candle light for 5 minutes. Observe and record the final temperature of the water.
5. Calculate the heat supplied by the candle using the formula $E_H = mc\Delta\theta$.

Expected Results

The temperature of the water will increase by as much as 5° or more.

PART B - THE IMPLEMENTATION

Method

1. The beaker was filled up to the 300 ml mark with distilled water and placed on the tripod stand.
2. Using the retort stand, the thermometer was secured at the centre of the beaker so that it does not touch the bottom of the beaker. The initial temperature of the water was measured and recorded.
3. The candle was placed directly under the tripod stand and lit. It was ensured the flame was as close to the bottom of the beaker as possible. The stop watch was started simultaneously.
4. The candle was allowed to be lit for 5 minutes .
5. The final temperature of the water after the five minutes was measured and recorded.
6. The heat supplied by the candle was calculated using the formula $E_H = mc\Delta\theta$.

Results

Initial Temperature of water [Θ_1] = 28°C

Final Temperature of water [Θ_2] = 34°C

Volume of water = 300 ml

Calculations:

Temperature change [$\Delta\Theta$] = $\Theta_2 - \Theta_1$ [note the temperature change in degrees Celsius is the same as in Kelvin] = 34 – 28 = 6 K

Mass of water = Volume of water × Density of water
= 300cm³ × 1g/cm³ = 300g = 0.3kg

E_H = mass of water × temperature change × specific heat capacity of water

E_H = 0.3 kg × 6 K × 4200 J/kg/K

E_H = 7560 J

Discussion

The amount of energy released by a candle in 5 minutes was of the order of several kilojoules. If the candle was lit for a longer period of time more energy would be released. It requires 90,720 J of heat energy to bring 300 g of water to its boiling point. According to the calculations, it would take the candle approximately 12 minutes to accomplish this task.

Limitations

Sources of Error/Limitation

Not all the heat energy produced by the candle was absorbed by the water. Some heat energy was absorbed by the beaker and tripod stand. Hence, the heat energy yielded for this experiment is only a fraction of the total heat energy produced by the candle.

Precautions

Read temperature perpendicular to the scale and above the meniscus.

Place candle as close to the beaker as possible

Reflections

Candles are commonly used during power outages as a source of light. A lit candle generates both light energy and heat energy. The latter being the greater energy produced. These cheap and common light sources can be dangerous if attention is not paid to how and where they are placed.

Conclusion

The heat energy released by the candle in 5 minutes is 7560 J.

Moderation of School-Based Assessment

The reliability (consistency) of the marks awarded by teachers on the School-Based Assessment is an important characteristic of high quality assessment. To assist in this process, the Council undertakes on-site moderation of the School-Based Assessment conducted by visiting external Moderators.

*During the Term 2 of Year 2, the Moderator will make a second visit. Teachers must make available to the Moderator **ALL** Assessment Sheets (Record of Marks, Mark Schemes and the report on the Investigation). **Teachers are NOT required to submit to CXC samples of candidates' work, unless specifically requested to do so by the Council BUT will be required to submit the candidates' marks electronically.***

The Moderator will remark the skills, and investigation reports for a sample of five candidates, who are selected using the guidelines listed below.

1. *Candidates' total marks on the SBA are arranged in descending order (highest to lowest).*
2. *The sample comprises the work of the candidates scoring the:*
 - (a) *highest Total mark;*
 - (b) *middle Total mark;*
 - (c) *lowest Total mark;*
 - (d) *mark midway between the highest and middle Total mark;*
 - (e) *mark midway between the middle and lowest Total mark;*
3. *The candidates selected above may be required to demonstrate some practical skills.*

Teachers' marks may be adjusted as a result of the moderation and feedback will be provided by the Moderator to the teachers.

*The Moderator may re-mark the assignments of additional candidates. Where the total number of candidates is five or fewer, the Moderator will remark **ALL**.*

On the first visit, the Moderator will re-mark a sample of the Year 1 candidates. A copy of this report must be retained by the teacher, and be made available to the Moderator during Term 2 of Year 2.

The Moderator will submit the Assessment Sheets, moderation of SBA Sample and the moderation reports to the Local Registrar by April 30 of the year of the examination. A copy of the Assessment Sheets and candidates' work must be retained by the school for three months after the examination results are published by CXC.

School-Based Assessment Record Sheets are available online via the CXC's website www.cxc.org.

All School-Based Assessment Record of marks must be submitted online using the SBA data capture module of the Online Registration System (ORS).

STRATEGIES FOR ASSESSING PRACTICAL OBJECTIVES

The basic strategy for assessing practical objectives in Physics comprises the following:

STEP I

Selection of the task or investigation and the corresponding syllabus objectives.

STEP II

1. Preparing the apparatus and the teacher performing the activity.
2. Determining and selecting skills to be assessed.
3. Developing the criteria for assessing each skill.
4. Designing rating scales based on the criteria.

STEP III

Breakdown of work to be done by candidate.

STEP IV

Carrying out assessment and recording marks.

Further explanation of Steps I-IV

The following is a more detailed explanation of what should take place in Steps I - IV.

Re: STEP I

The selection of the task or investigation should be done along with the preparation of the scheme of work for the term or year for each class. The task selected should contribute to the development of skills and attitudes within the subject and match a given syllabus objective (general or specific). Both qualitative and quantitative work should be included.

Re: STEP II

1. After selection of the task the teacher should prepare the required apparatus and materials. The teacher should perform the activity before presentation to the candidates as this can help in determining the steps involved and the skills that can be assessed (see Step III).
2. Before selecting the skills to be assessed the teacher should list all the skills that could be assessed. This may be achieved by preparing a step by step outline of the task and noting the skills involved in each step. Teachers are advised whenever possible to select only one skill to be assessed in any one activity.
3. Developing the criteria for assessing each skill is the most critical step in the assessment process. For a teacher to produce marks that are reliable the marking must be consistent for all candidates and the marks should reflect the standard of performance at the level. The teacher must be able to justify the marks and this occurs when there is a fixed set of conditions, factors or criteria for which the teacher looks.

CRITERIA FOR THE ASSESSMENT OF EACH SKILL

For each skill there may be a number of general criteria from which the teacher may select depending on the nature of the activity. It is especially important to make such a selection when there are numerous criteria as it is difficult to assess more than a few at a time without sacrificing accuracy. The following lists represent general criteria as may be defined under a particular skill:

A. OBSERVATION/RECORDING/REPORTING

- (i) Selects appropriate observations.
- (ii) Makes accurate recordings/observations.
- (iii) Uses appropriate format of presentation.
- (iv) Uses acceptable language/expression.
- (v) Uses appropriate tables/diagrams/graphs.

B. MANIPULATION/MEASUREMENT

- (i) Follows instructions.
- (ii) Uses basic laboratory equipment correctly.
- (iii) Sets up electrical circuits correctly.
- (iv) Uses electrical circuits correctly.
- (v) Prepares material for observation or investigation correctly.

C. PLANNING AND DESIGNING

- (i) Suggests appropriate hypotheses.
- (ii) Suggests suitable and feasible methods for data collection.
- (iii) Identifies and controls variables appropriately.
- (iv) Takes account of possible sources *of error or danger*.

D. ANALYSIS AND INTERPRETATION

- (i) Makes accurate calculations and logical inferences from data.
- (ii) Predicts from data.
- (iii) Evaluates data (including sources of error).
- (iv) Identifies relationships and patterns within data.

NOTE: Plotting and drawing of graphs would be assessed in Observation/Recording/Reporting whereas inferences from graphs would be assessed under Analysis and Interpretation.

Using a Checklist

Assessing candidates in some of the skills could be conveniently done by marking the candidates' laboratory notebooks. However, in the skills Manipulation/Measurement teachers will find it easier to write down marks as the activity is occurring. A convenient way of doing this is by using checklists. The column headings reflect what the teacher is looking for and a tick may be used to show that the candidate was displaying a satisfactory behaviour. More than one tick may occur in one column if the teacher checks a candidate more than once during the activity. A zero may be used to show that the candidate was displaying an unsatisfactory behaviour. The ticks and zeros should help the teacher decide on a mark for a candidate (see below).

CHECKLIST FOR USE OF A MEASURING CYLINDER

NAMES	Rests on flat surface	Meniscus read to avoid parallax	Bottom of meniscus read	MARK
L. Allie				
H. Cassie				
S. Williams				
D. Wong				

4. If the criteria are clear and adequate, a rating scale is relatively easy to define. The range required by the syllabus is an 11-point scale ranging from 0-10. If the number of criteria is small then several assessments may be necessary, perhaps of different pieces of apparatus in one activity.

It is important that a record of the criteria and rating scale used for each activity be kept to avoid duplication and it is advisable to submit, along with the final mark sheet of candidates' scores, a copy of such record.

Re: STEP III

The teacher should prepare a step by step outline of the task. Such an analysis would provide a good guide as to the format of the sessions, for example, work stations, groups, individual and worksheets, experimental format and the skills and objective(s) which may be assessed.

Re: STEP IV

A Teacher's Mark Book (which is retained by the school) should contain all the marks from which the averages are derived. The SBA Form which is submitted to CXC shows only the candidate's average mark at each point in each skill to be assessed at the point. At the end of this appendix is an example of the SBA Form and a possible format of a Teacher's Mark Book.

LABORATORY NOTEBOOKS

A sample of laboratory notebooks will be required to help moderate the teacher's scores.

1. The notebook should contain all the practical work that the candidate does (not only that which is assessed).
2. It is advisable for three pages to be left blank at the front of the practical notebook for a list of contents giving the practical activity and the date on which it was performed.
3. The activities used for SBA should be indicated.
4. The marks awarded for each skill selected within an activity should be indicated.
5. The notebooks should contain a variety of practical activities that are spread over the entire syllabus. Teachers may wish to consider some of the questions set by CXC in Question 1 of the Practical examination prior to 1997 as possible examples of open-ended investigative activities.

SELECTION OF ACTIVITIES

Teachers must bear in mind that opportunities for the development of the skills in the SBA are needed before their assessment. Again the point is made that practicals of a more open-ended, investigatory nature should also be utilized. Teachers should refer to the "Suggested Practical Activities" for ideas for practical work in the different section of the syllabus.

APPLYING THE ASSESSMENT STRATEGY

EXAMPLE

The following is an example of how the strategy may be applied to a specific task:

STEP I

To investigate the factors which might affect the period of simple pendulum (Specific Objective Section A 1.2).

STEPS II AND III

Apparatus per candidate or group

Stand or clamp, fine thread, several small objects of various masses for use as pendulum bobs, stop watch, metre rule.

1. Outline of task

- (a) Sets up apparatus appropriately.
- (b) Controls variables (in procedure).
- (c) Times several oscillations more than once.
- (d) Averages sensible results.
- (e) Compares results and draws appropriate conclusions.

2. Manipulation/Measurement is the skill selected for assessment.

3. Manipulation/Measurement

Criteria for assessment.

- (a) Uses vertical reference lines.
- (b) Measures length of pendulum to centre of bob.
- (c) Checks zero error on stop clock or stop watch.
- (d) Operates clock or watch correctly.
- (e) Uses count down method.
- (f) Reads scale to avoid parallax.

Note: The same experiment could have been used to assess Planning and Designing as follows:

Planning and Designing

- (i) identifies appropriate variables.
- (ii) maintains all but one variable constant for one series of readings.
- (iii) times a reasonable number of oscillations.
- (iv) repeats timing for same number of oscillations under same conditions.

4. Teacher's rating scale

STEP IV

Assessment performed and marks entered in Teacher's Mark Book.

RECORDING FOR SBA

Teacher's Mark Book

SKILL	OBSERVATION/RECORDING/REPORTING			MANIPULATION/MEASUREMENT			ANALYSIS AND INTERPRETATION			PLANNING AND DESIGNING			TOTAL			
	Date	18/1	Total	Out of 10	10/12	Total	Out of 10	25/1	28/3	Tot.	Out of 20	3/2		31/3	Tot.	Out of 20
Maximum Mark	12	12		8	4		10	15	10	25	14	8	9	17	20	60
Ammar, Annette	12	5	9	7	4	9	10	8	18	14	6	5	11		12	
McNab, Bryan	10	4	6	6	3	7	12	10	22	18	3	2	5	6		
Singh, Ricki	4	2	3	4	3	7	1	5	6	4	2	7	9	10		
Thompson, Neil	9	5	8	8	3	8	8	4	12	10	4	9	13	16		
Wong, Claudette	7	4	6	3	2	5	14	9	23	18	3	4	7	8		

Teacher's Mark Book

SKILL	OBSERVATION/RECORDING/REPORTING			MANIPULATION/MEASUREMENT			ANALYSIS AND INTERPRETATION			PLANNING AND DESIGNING			TOTAL
	Date	14/3	Tot.	Out of 20	20/4	Tot.	Out of 20	Tot.	Out of 10	3/2 31/3	Tot.	Out of 20	
Maximum Mark		6	27		4	18		25		8	17		70
Ammar, Annette		5	25		4	16		18		6	11		
McNab, Bryan		4	16		3	11		22		3	5		
Singh, Ricki		2	9		3	12		6		2	7		
Thompson, Neil		5	21		3	14		12		4	9		
Wong, Claudette		4	17		2	9		23		3	7		

N.B.:

- Although more than one skill may be assessed by any one component, the marks are more objective if the teacher concentrates on assessing one skill during a particular period of time.
- Note that no special assessment exercises need to be planned. The teachers will, as is customary, be recording periodic "marks" for their candidates. The difference is that, since these "marks" will now contribute to an assessment external to the school, they need to be more directed. Several of the objectives can be assessed from work which would normally be collected for marking.

CARIBBEAN EXAMINATIONS COUNCIL

SCHOOL-BASED ASSESSMENT IN PHYSICS7

NAME OF SCHOOL: _____

SCHOOL CODE: _____

YEAR OF FINAL EXAMINATION _____

NAME OF TEACHER: _____

TERRITORY: _____

REGISTRATION NUMBER	CANDIDATES NAME	YEAR 1				TOTAL	YEAR 2				TOTAL	TOTAL		COMMENTS	
		XS MM	XS ORR	XS PD	UK AI	Year 1	XS MM	XS ORR	XS PD	UK AI	Year 2	PROFILE			OVERALL
		P3 (10)	P3 (10)	P3 (20)	P2 (20)	60	P3 (20)	P3 (20)	P3 (10)	P2 (20)	70	P3 (90)	P2 (40)		

TEACHER'S SIGNATURE: _____

PRINCIPAL'S NAME: _____

DATE: _____

PRINCIPAL'S SIGNATURE: _____

◆ LIST OF PHYSICAL QUANTITIES AND THEIR SYMBOLS

NAME OF QUANTITY	SYMBOL	NAME OF QUANTITY	SYMBOL
ELECTRIC CURRENT	I	SPECIFIC LATENT HEAT	
LENGTH	l	OF FUSION	l_f
MASS	m	OF VAPORISATION	l_v
TEMPERATURE: (KELVIN) (CELSIUS)	T θ	WAVELENGTH	λ
TIME	t	PERIOD	T
VOLUME	V	AMPLITUDE	a
AREA	A	FREQUENCY	f
ANGLE	θ	OBJECT DISTANCE	u
DENSITY	ρ	IMAGE DISTANCE	v
RELATIVE DENSITY	ρ_r	FOCAL LENGTH	f
FORCE	F	REFRACTIVE INDEX	n
MOMENT OF FORCE OR TORQUE	T	LINEAR MAGNIFICATION	m
DISPLACEMENT, DISTANCE	s, x	ELECTRIC CHARGE	Q
SPEED, VELOCITY	v	POTENTIAL AND POTENTIAL DIFFERENCE	V
ACCELERATION	a	ELECTRO-MOTIVE FORCE	E
MOMENTUM	p	RESISTANCE	R
ENERGY	E, W	WEIGHT (GRAVITATIONAL FORCE)	W
WORK	W	ACCELERATION DUE TO GRAVITY	g
POTENTIAL ENERGY	E_p	MASS OF ELECTRON	m_e
KINETIC ENERGY	E_k	CHARGE OF ELECTRON	e
THERMAL ENERGY	E_H	PROTON (ATOMIC) NUMBER	Z
POWER	P	NUCLEON (MASS) NUMBER	A
PRESSURE	P	NEUTRON NUMBER	N
SPECIFIC HEAT CAPACITY	c	HALF LIFE	$T_{\frac{1}{2}}$
HEAT CAPACITY	C	VELOCITY OF LIGHT IN VACUO	c

◆ LIST OF GRAPHICAL SYMBOLS AS USED IN CIRCUIT DIAGRAMS

DESCRIPTION	GRAPHICAL SYMBOL(S)	DESCRIPTION	GRAPHICAL SYMBOL(S)
EARTH		GALVANOMETER	
CELL		SEMI-CONDUCTOR DIODE	
BATTERY OF CELLS		ELECTROLYTIC CELL OR VOLTAMETER	
D. C. SUPPLY		FUSE	
A. C. SUPPLY		FIXED RESISTOR	
SWITCH		VARIABLE RESISTOR	
JUNCTION OF CONDUCTORS		ELECTRIC MOTOR	
ONE WIRE CROSSING ANOTHER NO ELECTRICAL CONNECTION		LOUDSPEAKER	
FILAMENT LAMP OR BULB		TRANSFORMER	
VOLTMETER		GENERATOR	
AMMETER			

LIST OF GRAPHICAL SYMBOLS AS USED IN CIRCUIT DIAGRAMS (cont'd)

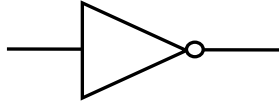
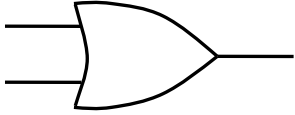
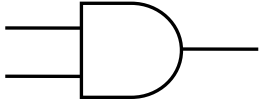
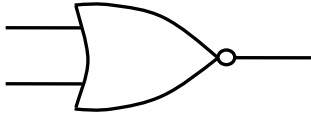
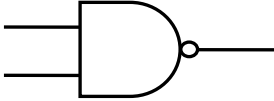
DESCRIPTION	GRAPHICAL SYMBOL(S)	DESCRIPTION	GRAPHICAL SYMBOL(S)
NOT		OR	
AND		NOR	
NAND			

RECOMMENDED MINIMUM EQUIPMENT LIST

(Recommended quantity per 25 candidates)

	QUANTITY	ITEM		QUANTITY	ITEM
1.	12	Metre rule	22.	12	Double pulley
2.	12	Half metre rule	23.	1	Manometer
3.	12	Callipers	24.	1	12m length of transparent PVC tubing diameter = 3cm
4.	12	Vernier callipers	25.	8	Sets brass masses (1 x 10g; 2x20g; 1x50g; 1x100g)
5.	12	Micrometer screwgauge	26.	12	Thermometer: -10°C to 110°C
6.	5	Top pan balance	27.	5	Clinical thermometer
7.	112	Spring balance (0 - 2.5)N	28.	1	Thermocouple
8.	1	Spring balance (0 - 10)N	29.	1	Ball and ring demonstration apparatus
9.	12	Stop watch (or clock)	30.	1	Bimetallic strip
10.	24	Retort stand and clamp/boss head	31.	20	Bunsen burner
11.	12	Pendulum bob	32.	12	Tripod stand and wire gauze
12.	5	Eureka/overflow can	33.	12	Beaker (100ml)
13.	2	Sets rectangular blocks of different materials having similar and different dimensions	34.	12	Beaker (250ml)
14.	12	Knife edge (commercial or improvised)	35.	12	Beaker (400ml)
15.	12	Helical spring yielding 0.5N cm^{-1}	36.	12	100 ml graduated measuring cylinder.
16.		Thread/String (as needed)	37.	6	1 metre length of glass tubing (each 4mm internal diameter).
17.	144	Straight (common) pin	38.	2	Glass funnel
18.	12	Set hook (stirrup) + set of slotted masses (10 x 100g)	39.	2	Sets rods of identical dimensions and different metals.
19.	2	Acceleration trolley	40.	1	Ripple tank and accessories
20.	1	Electronic timer	41.	1	Slinky spring
21.	12	Single pulley	42.	1	Bell jar, electric bell and vacuum pump apparatus.
			43.	12	Pinboard (of softwood or cardboard or polystyrene).

QUANTITY	ITEM	QUANTITY	ITEM		
44.	1	Ray optics kit	61.	1	Small d.c. motor (as from toy).
45.	100	Optical pins	62.	12	Variable resistors, commercial or improvised.
46.	12	Rectangular glass block	63.	2	Reel-resistance wire (bare) constantan (SWG 26)
47.	12	Right-angled triangular glass prism.	64.	2	Reel-resistance wire (bare) constantan (SWG 28).
	12	Equilateral triangular glass prism.			
48.	1	Light pipe	65.	2	Sets assorted standard resistors.
49.	12	Converging lens-focal length 10 cm	66.	12	Circuit key or switch.
50.	12	Converging lens-focal length 15 cm	67.	12	Diodes
51.	5	Diverging lens- any focal length.	68.	0.5kg	Copper sulphate (CuSO ₄ 5H ₂ O)
52.	12	Thin plane mirror (each 5cm x 8cm)	69.	1	Pair-copper electrodes (thick bare copper wire suitable)
53.	12	Power pack <u>OR</u> accumulator <u>OR</u> dry cells in holder or with soldered leads	70.	1	Card-fuse wire.
54.	5	Reel-varnished or insulated copper wire SWG 24.	71.	1	110 V plug
55.	12	Ammeter (0 - 1)A	72.	1	220 V plug.
	12	Voltmeter (0-5)V	73.	1	G.M. tube + electric accessories.
	12	Analog Multimeter	74.	1	α radioactive source.
56.	30	Doz. Crocodile clips	75.	1	β radioactive source.
57.	5	Small screwdrivers	76.	1	γ radioactive source.
58.	1	Pair of pliers or wire cutter	77.	1	Set of aluminium and lead plates.
			78.	1	Diffusion cloud chamber.
59.	24	2.5V (MES) torchlight electric lamp	79.	2	1 Set-identical dice.
60.	24	MES lamp holder	80.	2	Reel-PVC insulated connecting wire.

◆ RESOURCES

- Avison, J., Henry, D. and Neeranjan, *Physics for CSEC*, United Kingdom: Nelson Thornes Limited, 2007.
- Farley, A. and Trotz, C. *CXC Physics*, Oxford: Macmillan Education, 2007.
- Jackson, B. and Whiteley, P. *Physics for CSEC*, Jamaica: Carlong Publishers (Caribbean) Limited, 2007.

◆ GLOSSARY

WORD/TERM	DEFINITION/MEANINGS	NOTES
annotate	add a brief note to a label	{simple phrase of a few words only; KC}
apply	use knowledge and principles to solve problem	{make inferences and conclusions; UK}
assess	present reasons for the importance of particular structures, relationships or processes	{compare the advantages and disadvantages or the merits and demerits of a particular structure, relationship or process; UK}
calculate	arrive at the solution to numerical problem	{steps should be shown; units must be included; UK}
cite	quote or refer to	{KC}
classify	divide into groups according to observable characteristics	{UK}
comment	state opinion or view with supporting reasons	{UK}
compare	state similarities and differences	{an explanation of the significance of each similarity and difference stated may be required for comparisons which are other than structural; UK}
construct	use a specific format to make or draw a graph, histogram, pie chart or other representation using data or material provided or drawn from practical investigations, build (for example, a model) draw scale diagram	{such representation should normally bear a title, appropriate headings and legend; UK}
deduce	make a logical connection between two or more pieces of information; use data to arrive at a conclusion	{UK}
define	state concisely the meaning of a word or term	{this should include the defining equation or formula where relevant; KC}

WORD/TERM	DEFINITION/MEANINGS	NOTES
demonstrate	show, direct attention to...	{KC}
derive	to deduce, determine or extract from data by a set of logical steps some relationship, formula or result	{this relationship etc. may be general or specific; KC}
describe	provide detailed factual information on the appearance or arrangement of a specific structure or the sequence of a specific process	{descriptions may be in words, drawings or diagrams or any appropriate combination. Drawings or diagrams should be annotated to show appropriate detail where necessary; KC}
determine	find the value of a physical quality	{UK}
design	plan and present, with appropriate practical detail	{where hypotheses are stated or when tests are to be conducted, possible outcomes should be clearly stated the way in which data will be analyzed and presented; XS}
develop	expand or elaborate on an idea or argument with supporting reasons	{KC/UK}
differentiate or distinguish (between or among)	state or explain briefly those differences between or among items which can be used to define the items or place them into separate categories	{KC}
discuss	present reasoned argument; consider points both for an against; explain the relative merits of a case	{UK}
draw	make a line representation of apparatus which shows accurate relationship between the parts	{A diagram is a simplified representation showing the relationship between components; KC/UK}
estimate	make an approximate quantitative judgement	{UK}
evaluate	weigh evidence and make judgements based on given criteria	{the use of logical supporting reasons for a particular point of view is more important than the view held; usually both sides of an argument should be considered; UK}

WORD/TERM	DEFINITION/MEANINGS	NOTES
explain	give reasons, based on recall, to account for	{KC}
find	locate a feature or obtain as from a graph	{UK}
formulate	devise a hypothesis	{UK}
identify	name or point out specific components or features	{KC}
illustrate	show clearly by using appropriate examples or diagrams, sketches	{KC/UK}
investigate	use simple systematic procedures to observe, record data and draw logical conclusions	{XS}
label	add names to identify structures or parts indicated by pointers	{KC}
list	itemise without detail	{KC}
measure	take accurate quantitative readings using appropriate instruments	{XS}
name	give only the name of	{no additional information is required; KC}
note	write down observations	{XS}
observe	pay attention to details which characterise reaction or change taking place; to examine and note scientifically	{observations may involve all the senses or extensions of them but would normally exclude the sense of taste; XS}
plan	prepare to conduct an exercise	{XS}
predict	use information provided to arrive at a likely conclusion or suggestion possible outcome	{UK}
record	write an accurate description of the full range of observations made during a given procedure	{this includes the values for any variable being investigated; where appropriate, recorded data may be depicted in graphs, histograms or tables; XS}

WORD/TERM	DEFINITION/MEANINGS	NOTES
relate	show connections between; explain how one set of facts or data depend on others or are determined by them	{UK}
sketch	Make a simple freehand diagram showing relevant proportions and any important details	{KC}
state	provide factual information in concise terms omitting explanations	{KC}
suggest	Offer an explanation deduced from information provided or previous knowledge. (... an hypothesis; provide a generalisation which offers a likely explanation for a set of data or observations.)	{no correct or incorrect solution is presumed but suggestions must be acceptable within the limits of scientific knowledge; UK}
test	to find out following set procedures	{XS}

KEY TO ABBREVIATIONS

KC	-	Knowledge and Comprehension
UK	-	Use of Knowledge
XS	-	Experimental Skills

Western Zone Office
12 June 2013



FORM 01238010/SPEC

CARIBBEAN EXAMINATIONS COUNCIL

CARIBBEAN SECONDARY EDUCATION CERTIFICATE®
EXAMINATION

PHYSICS

SPECIMEN PAPER

Paper 01 – General Proficiency

75 minutes

READ THE FOLLOWING INSTRUCTIONS CAREFULLY

1. This paper consists of 60 items. You will have 75 minutes to answer them.
2. In addition to this test booklet, you should have an answer sheet.
3. Each item in this test has four suggested answers, lettered (A), (B), (C) and (D). Read each item you are about to answer and decide which choice is best.
4. On your answer sheet, find the number which corresponds to your item and shade the space having the same letter as the answer you have chosen. Look at the sample item below.

Sample Item

The SI unit of length is the

- (A) metre
 (B) newton
 (C) second
 (D) kilogram

Sample Answer

The best answer to this item is “metre”, so answer space (A) has been shaded.

5. If you want to change your answer, erase it completely and fill in your new choice.
6. When you are told to begin, turn the page and work as quickly and as carefully as you can. If you cannot answer an item, omit it and go on to the one. You can return later to the item omitted. Your score will be the number of correct answers produced.
7. You may do any rough work in the booklet.
8. Figures are not necessarily drawn to scale.
9. The use of silent electronic calculators is allowed.

DO NOT TURN THIS PAGE UNTIL YOU ARE TOLD TO DO SO

1. Which of the following is a vector quantity?

- (A) Mass
- (B) Density
- (C) Moment
- (D) Momentum

2. Which arrangement gives the greatest resultant force acting on the block?

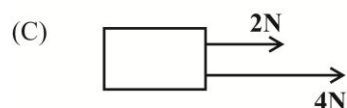
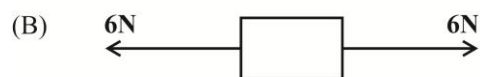
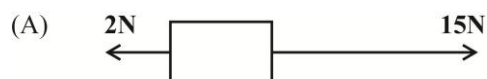

3. Which of the following is a non-renewable energy source?

- (A) Biomass
- (B) Wind
- (C) Natural Gas
- (D) Sun

4. Item 4 refers to the lamps below.

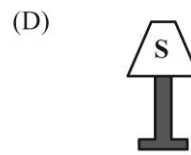
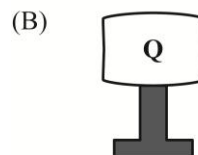
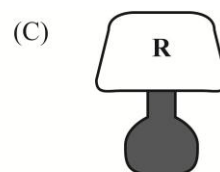
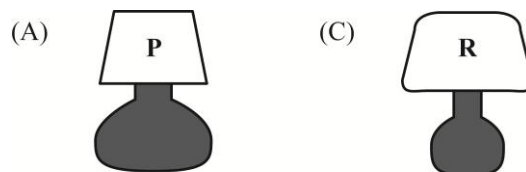

The most stable lamp is

- (A) P
- (B) Q
- (C) R
- (D) S

5. Which of the following is MOST suitable for measuring the diameter of a wire?

- (A) Metric rule
- (B) Tape measure
- (C) Vernier calipers
- (D) Micrometer screw gauge

6. Which of the following is the correct SI unit for pressure?

- (A) Joule (J)
- (B) Pascal (Pa)
- (C) Newton-metre (Nm)
- (D) Newton per metre (Nm^{-1})

7. A vehicle with a uniform velocity of 10ms^{-1} is represented by which of the following graphs?

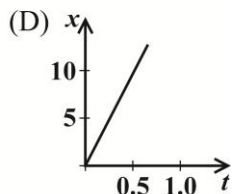
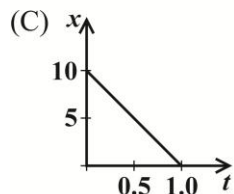
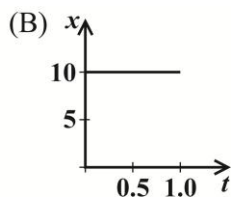
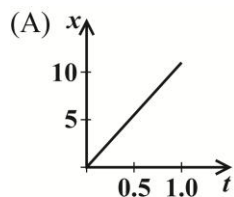

8. Which of the following is NOT a vector quantity?

- (A) Mass
(B) Force
(C) Velocity
(D) Acceleration

9. Force is directly proportional to

- (A) velocity
(B) acceleration
(C) displacement
(D) momentum

10. A cyclist riding down a hill applies his brakes and eventually comes to rest at the bottom of the hill. Which of the following energy changes takes place?

- (A) Potential \rightarrow kinetic
(B) Potential \rightarrow kinetic \rightarrow heat
(C) Kinetic \rightarrow potential \rightarrow heat
(D) Potential \rightarrow kinetic \rightarrow chemical

11. Acceleration can be defined as the rate of change of

- (A) velocity
(B) energy
(C) momentum
(D) displacement

12. Which of the following does the pressure of a fluid depend?

- I. The depth of the fluid
II. The density of the fluid
III. The acceleration due to gravity

- (A) I only
(B) II only
(C) I and II only
(D) I, II and III

13. The period of a simple pendulum depends on

- (A) The length of the string
(B) The mass of the bob
(C) The initial displacement
(D) The stop watch used

14. An aeroplane is travelling at a constant speed at an altitude of 1000 m above sea level. Which of the following is TRUE?

- (A) Its kinetic energy is increasing
(B) It has kinetic energy only
(C) It has potential energy only
(D) It has both potential and kinetic energy

15. Which of the following is TRUE of a body in equilibrium.

- I. The sum of the forces in one direction is equal to the sum of the forces in the opposite direction
- II. The sum of the clockwise forces is equal to the sum of the anticlockwise forces
- III. The sum of the clockwise moments is equal to the sum of the anticlockwise moments

- (A) I only
- (B) II only
- (C) I and III only
- (D) I, II and III

16. 400 kg of methylated spirit occupies a volume of 0.50 m^3 . What is its density?

- (A) $8 \times 10^2 \text{ kg m}^{-3}$
- (B) $8 \times 10^{-2} \text{ kg m}^{-3}$
- (C) $2 \times 10^2 \text{ kg m}^{-3}$
- (D) $1.25 \times 10^{-3} \text{ kg m}^{-3}$

17. What is the gain in gravitational potential energy of a body of weight 2000 N as it rises from a height of 20 m to a height of 25 m above the earth's surface?

- (A) 400 J
- (B) 1 000 J
- (C) 10 000 J
- (D) 20 000 J

18. When liquid in a puddle evaporates its temperature changes. How does the temperature of the liquid change and why?

	Temperature	Reason
(A)	decreases	less energetic molecules leave the liquid
(B)	decreases	more energetic molecules leave the liquid
(C)	increases	less energetic molecules leave the liquid
(D)	increases	more energetic molecules leave the liquid

19. Which scientist successfully showed the relationship between heat and mechanical work?

- (A) Joule
- (B) Einstein
- (C) Rumford
- (D) Watts

20. A thermostat used in a domestic iron is made from a bimetallic strip comprising of a strip of iron and a strip of brass as shown below.

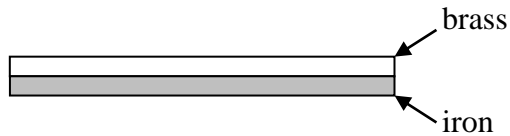

The strip is heated and the brass expands more than the iron.
The shape the strip becomes:

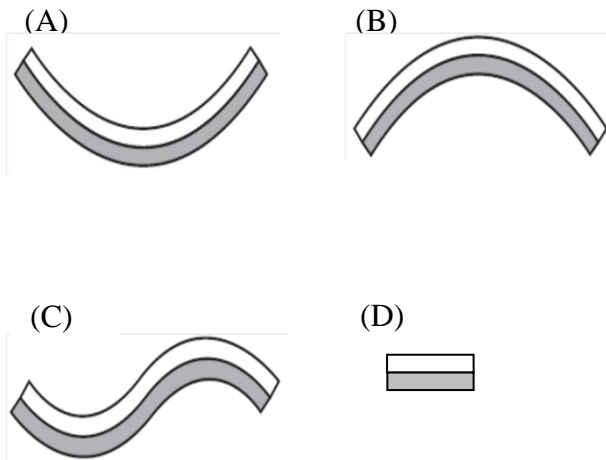

21. The name given to the amount of energy needed to raise the temperature of 1kg of iron by 1 K is

- (A) latent heat
(B) heat capacity
(C) specific latent heat
(D) specific heat capacity

22. Sharon painted half the roof of her dog house white and the other half black. She noticed that the half painted black dried quicker than the half painted white.

The property that BEST explains why the half painted black dried quicker is that dark bodies are better

- (A) insulators.
(B) heat absorbers
(C) reflectors of heat
(D) conductors of heat

23. Bubbles of gas rising from a scuba diver below the surface of the sea increase in size as they rise to the surface. Their size increase is because

- (A) Water pressure on the bubbles decreases
(B) Water pressure on the bubbles increases
(C) Atmospheric pressure on the bubble decreases
(D) Atmospheric pressure on the bubbles increases

24. The clinical thermometer is designed so that it is very sensitive to small changes in temperature.

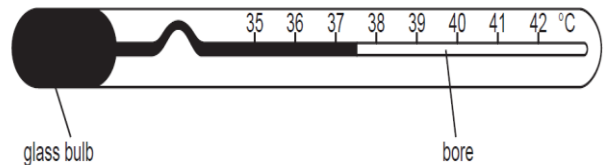

Which of the following features should it have?:

- (A) A thick-walled bulb and a wide bore
(B) A thin walled bulb and a wide bore
(C) A thin-walled bulb and a narrow bore
(D) A thick-walled bulb and a narrow bore
25. In a YouTube video, Mr. Lee and his students heat a metal drum which is then capped and dumped into a tub of cold water. The video shows that the drum is crushed.

The gas law that BEST explains this observation is due to

- (A) Boyle's
(B) Charles'
(C) Pressure
(D) Combined Gas

26. An electronic air conditioner maintains the temperature of the inside of an office building at 24°C . Which of the following measures could noticeably reduce the electricity bill?

- I. Reducing the temperature to 21°C
- II. Hanging curtains at the window
- III. Painting the roof of the building with aluminum paint

- (A) I only
- (B) I and II only
- (C) II and III only
- (D) I, II and III

27. Item 27 refers to the diagram below.

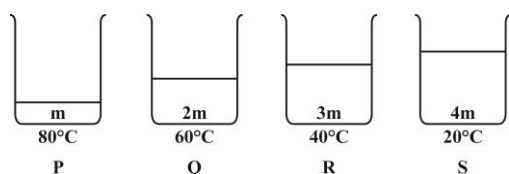

In the diagram above, P, Q, R and S are identical containers containing water of masses m , $2m$, $3m$ and $4m$ respectively at the temperatures indicated. Which of the following must lose the most energy to cool down to 10°C ?

- (A) P
- (B) Q
- (C) R
- (D) S

28. Item 28 refers to the following table.

Pressure/kPa	Volume/ cm^3
1.0	40
1.3	30

The table shows two pairs of readings taken from an experiment to investigate Boyle's law. Which of the values below is MOST likely to be the measured pressure if the volume is reduced to 20 cm^3 ?

- (A) 0.5 kPa
- (B) 1.6 kPa
- (C) 1.9 kPa
- (D) 2.3 kPa

29. Lightning is seen several seconds before thunder is heard because

- (A) thunder is produced after the lightning
- (B) light can pass through a vacuum but sound cannot
- (C) the speed of light is much faster than the speed of sound
- (D) sound is reflected by the clouds several times before it reaches the ear.

30. The list of electromagnetic waves in order of DECREASING wave length is

- (A) Xrays, ultraviolet, infrared, microwaves
- (B) Xrays, infrared, ultraviolet, microwaves
- (C) Microwaves, ultraviolet, infrared, x rays
- (D) Microwaves, infrared, ultraviolet, x-rays.

Item 31 refers to the following diagram

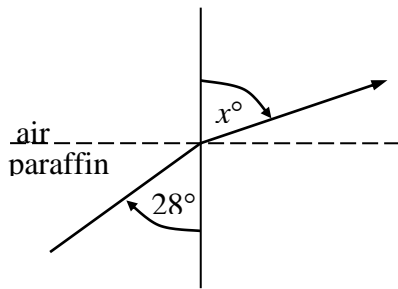

31. A ray of light passes from paraffin into air at an angle of incidence of 28° . If the refractive index of paraffin is 1.44, the value of $\sin x^\circ$ is
- (A) $\frac{1.44}{\sin 28^\circ}$
 (B) $1.44 \times \sin 28^\circ$
 (C) $\frac{\sin 28^\circ}{1.44}$
 (D) $\frac{1.44}{\sin 62^\circ}$

Item 32 refers to the following diagram

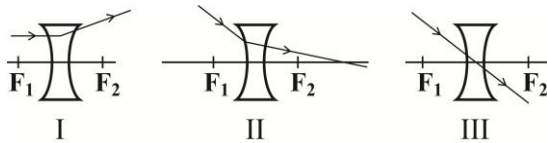

32. Which shows a ray of light passing through a diverging lens?
- (A) II only
 (B) I and II only
 (C) I and III only
 (D) I, II and III
33. The refractive index for light traveling from air to glass is
- I. $\frac{\text{speed of light in glass}}{\text{speed of light in air}}$
 II. $\frac{\text{wave length of light in air}}{\text{wave length of light in glass}}$
 III. $\frac{\text{frequency of light in air}}{\text{frequency of light in glass}}$
- (A) II only
 (B) I and II only
 (C) II and III only
 (D) I, II and III

Item 34 refers to the following diagram

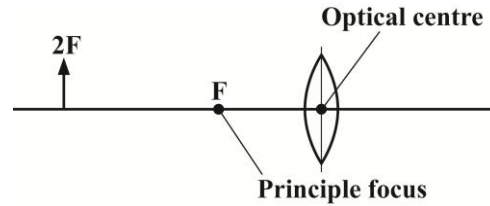

34. From the diagram above, a real image is produced with a converging lens when the object is located
- (A) At F only
 (B) At $2F$ only
 (C) Between F and infinity
 (D) Between the optical centre and F
35. When Young's Double Slit experiment is conducted, it is expected to show
- (A) That light can bend
 (B) A series of dots on a screen
 (C) That light travels in a straight line
 (D) Interference patterns on a screen
36. "Pitch" and "loudness" refer respectively to
- (A) Amplitude and frequency
 (B) Frequency and amplitude
 (C) Wavelength and speed
 (D) Speed and wavelength

Item 37 refers to the following diagram.

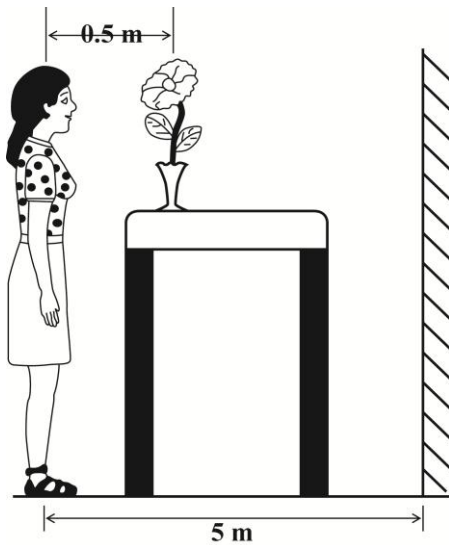

37. A lady faces a plane mirror which is 5.0 m away from her. She views the image of a vase, which is 0.5 m in front of her. How far from her is the image of the vase?

(A) 4.5 m
 (B) 5.5 m
 (C) 9.0 m
 (D) 9.5 m

38. A transmitter emits radio waves of frequency 750 kHz. If the velocity of electromagnetic waves is $3 \times 10^8 \text{ m s}^{-1}$, what is the wavelength of the transmission?

(A) 200 m
 (B) 250 m
 (C) 400 m
 (D) 800 m

Item 39 refers to the following diagram, which shows two resistors, $R_1 = 6.0 \Omega$ and $R_2 = 4.0 \Omega$, in parallel.

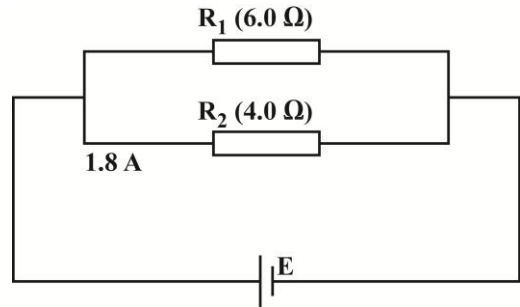

39. What is the current in R_1 if the current in R_2 is 1.8 A?

(A) 1.2 A
 (B) 1.8 A
 (C) 2.7 A
 (D) 3.0 A

40. A transformer was connected to a 100 V supply and the output measured and found to be 10 V, 0.5 A. The primary current was

(A) 0.005 A
 (B) 0.05 A
 (C) 0.5 A
 (D) 5.0 A

Item 41 refers to the truth table below

A	B	C
0	0	1
0	1	1
1	0	1
1	1	0

41. The logic gate that gives the above output is

(A) OR
 (B) AND
 (C) NOR
 (D) NAND

42. If in a transformer, N_S is greater than N_P , then the transformer is a
- (A) Smoothing transformer
 - (B) Step – up transformer
 - (C) Alternating transformer
 - (D) Step-down transformer
43. Which of the following quantities is constant in a parallel circuit?
- (A) Current
 - (B) Voltage
 - (C) Resistance
 - (D) Power
44. A magnetic field can be used to deflect the path of
- (A) β -rays
 - (B) γ - rays
 - (C) X-rays
 - (D) Light rays
45. Which of the following scientists discovered the relationship $E = mc^2$?
- (A) Marie Curie
 - (B) Isaac Newton
 - (C) Albert Einstein
 - (D) Ernest Rutherford
46. For any TWO consecutive elements in the periodic table the first element has one less
- (A) proton
 - (B) electron
 - (C) neutron
 - (D) neutrino
47. For a radioactive substance with a particular half-life, as time increases, the radioactive substance
- (A) vanishes
 - (B) increases
 - (C) decreases
 - (D) remains constant
48. What did the Geiger-Marsden experiment establish as being present in the atom?
- (A) Electrons
 - (B) Nucleus
 - (C) Neutrons
 - (D) Electrical forces
49. The atomic number and the mass number of an atom are 50 and 120 respectively. This means that in the atom there are
- (A) 120 protons
 - (B) 120 neutrons
 - (C) 70 protons and 50 neutrons
 - (D) 50 protons and 70 neutrons
50. On Sunday, the corrected count rate of a radioactive source was 240 counts per second. Exactly two days later, the count rate had fallen to 120 counts per second. After exactly four more days (on Saturday), the count rate in counts per second was
- (A) zero
 - (B) 24
 - (C) 30
 - (D) 60

51. When a polythene rod is rubbed with a cloth, it becomes

- (A) Positively charged by losing electrons
- (B) Positively charged by gaining protons
- (C) Negatively charged by losing electrons
- (D) Negatively charged by gaining electrons

52. The role of a transformer in an electrical circuit is to

- (A) alter the voltage
- (B) alter the frequency
- (C) convert alternating current to direct current
- (D) convert direct current to alternating current

53. Which of the following materials are conductors?

- I. Wood
- II. Gold
- III. Graphite

- (A) I and II only
- (B) I and III only
- (C) II and III only
- (D) I, II and III

54. Fleming's left hand rule associates a quantity with each finger shown in the diagram below. The correct **ORDER** of the quantities labelled **i**, **ii** and **iii** is

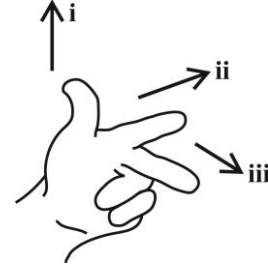

- (A) Current, Force, Field
- (B) Field, Current, Force
- (C) Field, Force, Current
- (D) Force, Field, Current

55. A student requires a circuit to measure the resistance of a resistor. Which of the circuits below is correctly connected?

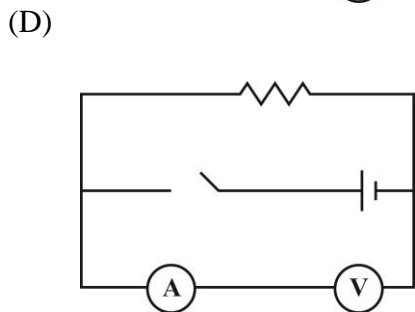
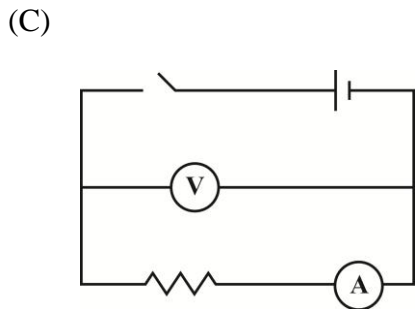
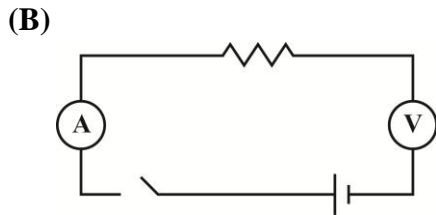
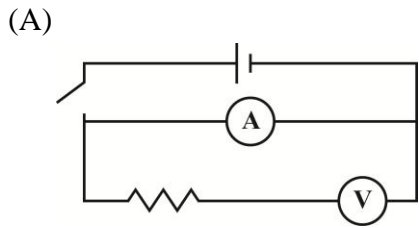

Item 56 refers to the following circuit.

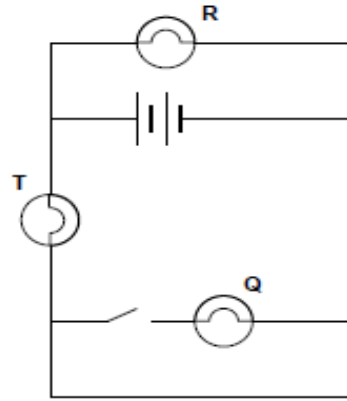

56. In the circuit shown above, which lamps will be lit when the switch is closed?

- (A) R only
- (B) T, Q and R
- (C) T and Q only
- (D) T and R only

Item 57 refers to the following diagram which shows a coil carrying a current and wrapped around wooden cylinder.

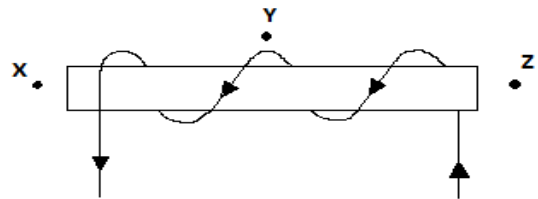

57. Which row of the table below shows the magnetic field directions at x, y and z?

	x	y	z
(A)	←	→	←
(B)	→	←	→
(C)	→	←	←
(D)	→	→	→

58. Which of the following is **NOT TRUE** when a magnet is moved relative to a coil?

- I. The greater the number of turns in the coil, the smaller the induced e.m.f.
 - II. The faster the magnet moves relative to the coil, the greater the induced e.m.f.
 - III. The stronger the magnetic field, the greater the induced e.m.f.
- (A) I only
 (B) II only
 (C) III only
 (D) II and III only

Item 59 refers to the diagram below.

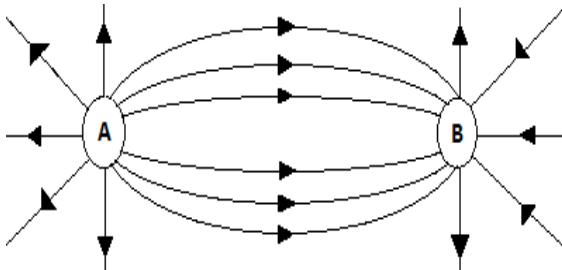

59. In the electric field diagram above the charges labelled A and B are

- (A) Positive and positive
- (B) Negative and positive
- (C) Negative and negative
- (D) Positive and negative

60. The radioactive decay of an isotope of Radon is represented by the equation

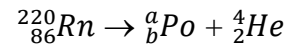

The values of a and b are respectively

- | | a | b |
|-----|-----|-----|
| (A) | 216 | 88 |
| (B) | 216 | 84 |
| (C) | 220 | 84 |
| (D) | 220 | 83 |

**CARIBBEAN EXAMINATION COUNCIL
SECONDARY EDUCATION CERTIFICATE
PHYSICS SPECIMEN PAPER 2012**

Item	Specific Objective	Key	Item	Specific Objective	Key
1	A2.1	D	31	C4.10	B
2	A.2.3	A	32	C5.1	C
3	A5.5	C	33	C4.10	A
4	A3.12	A	34	C5.3	C
5	A1.9	D	35	C4.2	D
6	A6.1	B	36	C2.2	B
7	A4.2	A	37	C4.5	D
8	A2.1	A	38	C1.2	C
9	A4.4	B	39	D4.11	A
10	A5.10	B	40	D7.16	B
11	A4.1	A	41	D5.4	D
12	A6.1	C	42	D7.14	B
13	A1.2	A	43	D4.11	B
14	A5.6	D	44	E3.5	A
15	A3.9	C	45	E3.12	C
16	A 1.10	A	46	E2.6	A
17	A5.7	C	47	E3.10	C
18	B3.7	B	48	E1.2	B
19	B1.2	A	49	E2.4	D
20	B2.8	B	50	E3.10	C
21	B3.1	D	51	E1.1	D
22	B4.5	B	52	D7.14	A
23	B2.11	A	53	D2.1	C
24	B2.3	C	54	D7.6	D
25	B2.11	B	55	D4.1	C
26	B4.6	C	56	D4.2	D
27	B3.2	B	57	D7.2	B
28	B2.11	C	58	D7.11	A
29	C2.3	C	59	D1.4	D
30	C3.2	D	60	E3.6	B



FORM 01238020/SPEC

**CARIBBEAN EXAMINATIONS COUNCIL
CARIBBEAN SECONDARY EDUCATION CERTIFICATE®
EXAMINATION**

PHYSICS

SPECIMEN PAPER

Paper 02 – General Proficiency

2 hours and 30 minutes

READ THE FOLLOWING INSTRUCTIONS CAREFULLY.

1. This paper consists of **SIX** questions in two sections. Answer **ALL** questions.
2. For Section A, write your answers in the spaces provided in this booklet.
3. For Section B, write your answers in the spaces provided at the end of each question, in this booklet.
4. All working **MUST** be **CLEARLY** shown.
5. The use of non-programmable calculators is permitted, but candidates should note that the use of an inappropriate number of figures in answers will be penalized.
6. Mathematical tables are provided.

SECTION A**Attempt ALL questions****You MUST write your answers in this answer booklet.**

1. Rihanna, a student, carried out an experiment to investigate the properties of a spring. The results of the variation of the length of the spring with load, is shown in Table 1.

TABLE 1

Load (N)	4.0	8.0	12.0	16.0	20.0	24.0
Length (mm)	18.4	20.5	22.4	24.3	26.4	28.5

- (a) On the grid provided on page 3, plot the graph of Length (mm) against Load (N).

(7 marks)

- (b) Calculate the slope, P, of the graph.

(4 marks)

- (c) Given that the spring constant equal $\frac{1}{P}$, calculate the spring constant stating its units.

(2 marks)

- (d) Use your graph to determine the spring's length when the load is 0N.

(1 mark)

GO ON TO THE NEXT PAGE

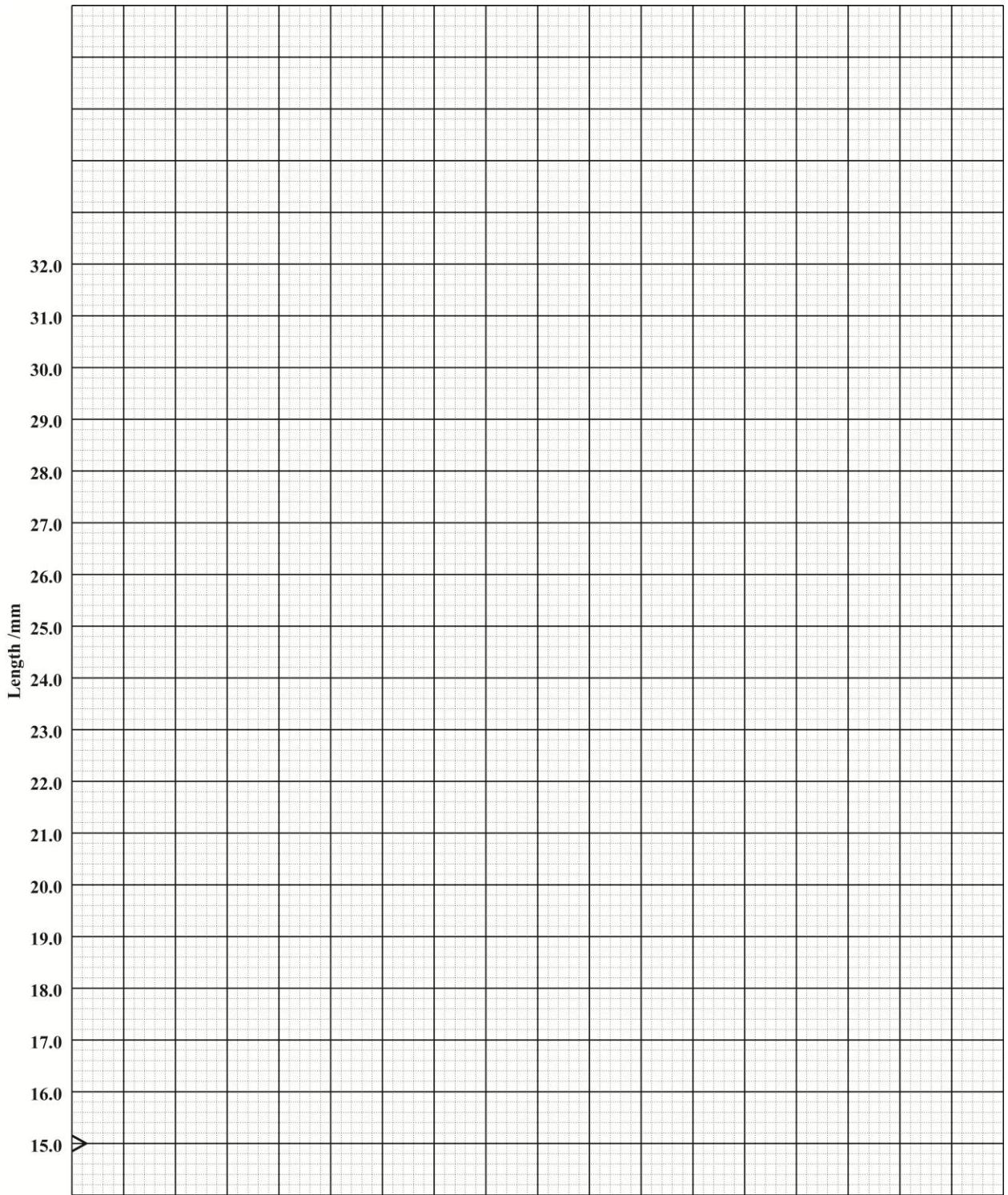

- (e) What mass must be placed on the spring to produce an extension of 9mm?

(7 marks)

- (f) State THREE precautions Rihanna would have taken to ensure the accuracy of the readings and to prevent damage to the spring.

(3 marks)

Total 25 marks

2. (a) Draw a circuit with three resistors in parallel across a two-cell battery. Include an ammeter in the circuit so that its reading is the total current in the circuit.

(3 marks)

- (b)(i) Give the equation relating resistance, voltage and current. State the unit for resistance.

(2 marks)

GO ON TO THE NEXT PAGE

- (ii) Explain whether or not an ammeter should have a high resistance?

(2 marks)

- (c)(i) If the three resistors in 2(a) are each 2Ω , what is the total effective resistance in the circuit?

(2 marks)

- (ii) The voltage supplied by the two-cell battery is 3V. What is the reading on the ammeter?

(3 marks)

- (iii) If the ammeter is replaced by one which has a resistance of 3Ω , calculate the new reading.

(3 marks)

Total 15 marks

3. (a) Distinguish between the mode of propagation of transverse waves and longitudinal waves.

(2 marks)

(b) Give ONE example of EACH of the following waves:

Longitudinal: _____

Transverse: _____

(2 marks)

(c) Define the following terms:

(i) wavelength

(ii) frequency

(iii) amplitude

(3 marks)

- (d) (i) Draw a wave of wavelength 6 cm using the axes provided in Figure 1.

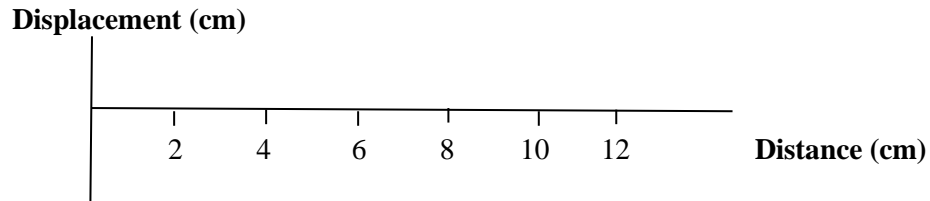

Figure 1

(2 marks)

Figure 2 shows a displacement-time graph of a small Styrofoam cup floating, in the path of water wave in a pond.

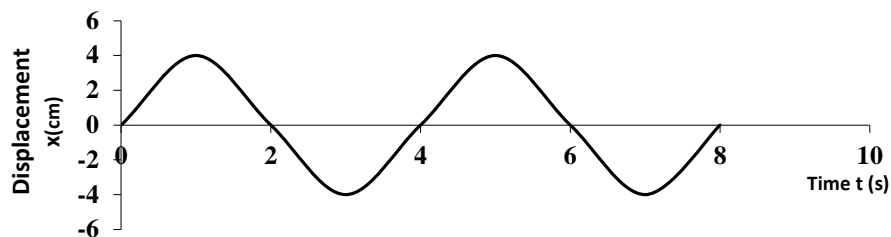

Figure 2

- (ii) Use the graph in Figure 2 to determine the frequency of the wave.

(3 marks)

- (iii) Use the graph to determine the amplitude of the wave.

(1 mark)

- (e) Give ONE example of the use of waves in each of the following:

Medical testing _____

Industry _____

(2 marks)

Total 15 marks

GO ON TO THE NEXT PAGE

SECTION B

Attempt ALL questions

You MUST write your answers in the space provided after each question.

4. (a) A typical lap top computer operates on 18 V d.c. As a result, to safely power a lap top from 120V a.c. domestic mains, a specialized power cable must be used.
- (i) State the TWO essential components that must be included in this specialized cable. (2 marks)
- (ii) Sketch TWO separate graphs to show the variation of voltage vs. time of a 120 V a.c. domestic mains and the output of the specialized power cable. Assume that the power cable is only able to accomplish $\frac{1}{2}$ wave rectification. (4 marks)
- (b) An electric kettle is connected to an alarm that sounds whenever the kettle is switched on and the lid is left open or the water level is below the heating element. Figure 3 shows the circuit that controls the electric kettle's alarm.

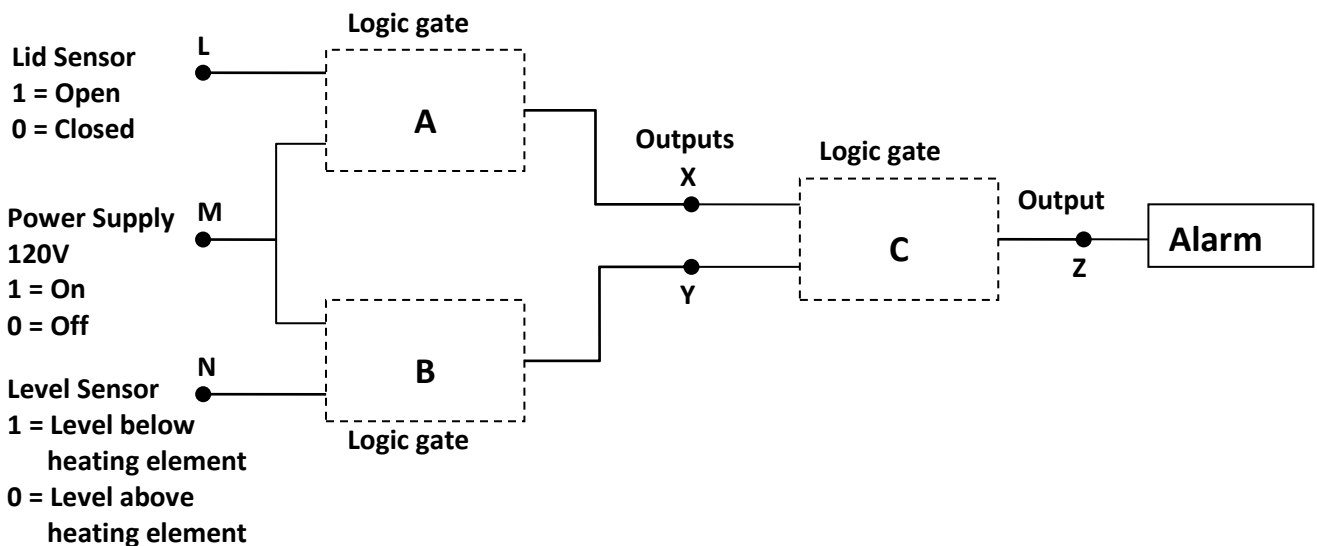

Figure 3

- (i) What are points **L**, **M** and **N** collectively called? (1 mark)
- (ii) What logic gate(s) should be placed at **A**, **B** and **C**? (3 marks)

GO ON TO THE NEXT PAGE

- (iii) The table below shows the inputs for a truth table. In the space provided for your answers, complete the truth table to show outputs at **X**, **Y** and **Z** that satisfies the condition that will make the alarm sound.

Input		
L	M	N
0	0	0
0	0	1
0	1	0
0	1	1
1	0	0
1	0	1
1	1	0
1	1	1

(3 marks)

- (c) Discuss ONE way in which lap top computers have evolved into a versatile tool of communication.

(2 marks)

Total 15 marks

Write the answer to Question 4 here.

(b) (iii)

Input			Output		
L	M	N	X	Y	Z
0	0	0			
0	0	1			
0	1	0			
0	1	1			
1	0	0			
1	0	1			
1	1	0			
1	1	1			

- 6 (a) (i) Define the term specific latent heat of vaporisation. **(2 marks)**
- (ii) Identify THREE processes that require specific latent heat. **(3 marks)**
- (b) An electric kettle is rated at 1500W. It takes 98s to bring water originally at 30°C to 100°C.
- (i) Describe the energy change that takes place in the kettle. **(1 mark)**
- (ii) How much energy is supplied by the kettle in the given time? **(3 marks)**
- (iii) Calculate the specific heat capacity of the water. **(3 marks)**
- (iv) 0.1 Kg of water is converted to steam when the kettle is left on for an additional 150s. Calculate a value for the specific latent heat of vaporisation of steam. **(3 marks)**

Total 15 marks

Write the answer to Question 6 here.

GO ON TO THE NEXT PAGE

C A R I B B E A N E X A M I N A T I O N S C O U N C I L

CARIBBEAN SECONDARY EDUCATION CERTIFICATE®
EXAMINATION

PHYSICS

SPECIMEN PAPER

PAPER 02 - GENERAL PROFICIENCY

MARK SCHEME

2012

Question 1 P2	MARK SCHEME	KC	UK	XS
1 (a)	L-Label axes (1) A-correct Axes Length on y-axis and load on x-axis (1) S-scales (1) P-Plots 6-5 correct -3 4-3 correct -2 2-1 correct -1 Best fit line (1)			7
(b)	Large Δ (1) Correct read offs = $\frac{28.60-17}{25-1.4} = \frac{11.60}{22.6}$ (1) gradient formula = $\frac{AB}{BC}$ (1) Answer = $0.55 \pm 0.05 \text{ mmN}^{-1}$ (1)		3	2
(c)	Spring's constant = $\frac{1}{P} = \frac{1}{0.55}$ (1) = 1.81 Nmm^{-1} (1)		2	
(d)	Spring's length = <u>16.3</u> mm (1)			1
(e)	Original length = 16.3 mm New Length of spring = Original length + Extension (1) = 16.3 mm + 9 mm (1) = 25.3 mm (1)			
SP. OBJ				

Question 1 Cont'd	MARK SCHEME	KC	UK	XS
(e) c'td	Corresponding Load = 17.5 N (1) Load = mg (1) $17.5 = m \cdot 10$ (1) $m = \frac{17.5}{10}$ $m = 1.75 \text{ Kg}$ (1)		7	
(f)	(i) Avoid the error of parallax by reading the scale accurately. (1) (ii) Do not overload the spring to prevent permanent damage. (1) (iii) Add loads when the system comes to rest. (1) (iv) Take measurements when the system comes to rest. (1) Any 3: 1 mark each.	3		
SP. OBJ	A 1.4, 1.5, 3.13	Total	3	12
			12	10

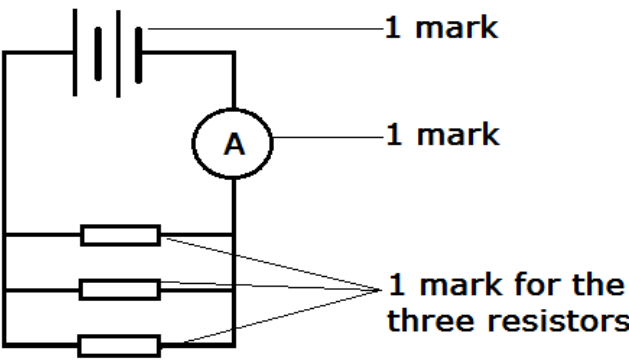
Question 2	MARK SCHEME	KC	UK	XS
2a.		3		
b (i)	Resistance = V/I . (1) The unit of resistance is the Ohm[Ω]. (1)	2		
(ii)	It must offer no resistance to current flow - the circuit must function as if the ammeter is not in the circuit. (1)	2		
(c) (i)	$1/R_T = 1/R_1 + 1/R_2 + 1/R_3$ (1) $1/R_T = \frac{1}{2} + \frac{1}{2} + \frac{1}{2}$ (1) $1/R_T = 3/2$ (1) $R_T = 2/3\Omega$ or 0.67Ω (1)		2	
(ii)	$V = IR$ (1) $I = V/R = \frac{3V}{\frac{2}{3}}$ (1) $= 4.5A$ (1)		3	
(iii)	$R_T = 3\Omega + 0.67\Omega = 3.67\Omega$ (1) $I = 3V/3.67\Omega$ (1) $= 0.82A$ (1)		3	
SP. OBJ	D 4.7, 4.9 Total	7	8	

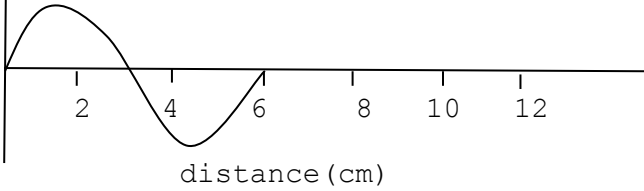
Question 3	MARK SCHEME	KC	UK	XS
(a)	For propagation of <u>transverse</u> waves, the displacement of the medium is <u>perpendicular</u> to the direction of motion while for propagation of <u>longitudinal</u> waves, the displacement of the medium is <u>parallel</u> to the propagation of the wave.		1 1	
(b)	Examples: transverse wave - electromagnetic / water waves Longitudinal wave - sound waves	1 1		
(c) (i)	Wavelength: The distance between successive crests or troughs of a wave	1		
(ii)	Frequency: Number of waves per unit time	1		
(iii)	Amplitude: This is the maximum displacement of the wave	1		
(d) (i)	<p>displacement (cm)</p>  <p>distance (cm)</p> <p>1 mark for general sinusoidal shape 1 mark for crossing at 3 cm and ending on 6 cm</p>		2	
(ii)	<p>Frequency = Number of waves / time = 1 / 4 f = 0.25 /seconds</p> <p>(1) (1) (1)</p> <p>marks for equation, substitution, correct answer</p>		3	
(iii)	Amplitude of the wave = 4 cm (1)		1	
(e)	Example in medical testing: ultrasound in prenatal care (1)			
	Example in industry: testing of materials for defects (1)	2		
SP. OBJ	C 1.1,1.2,2.5	7	8	
	Total			

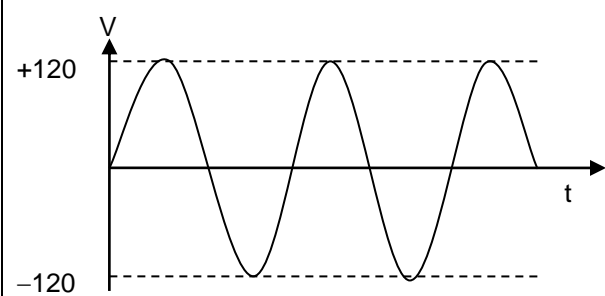
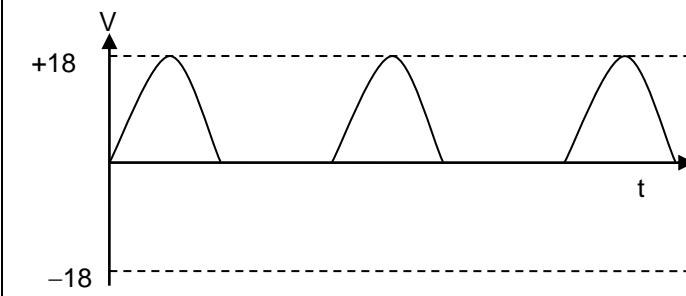
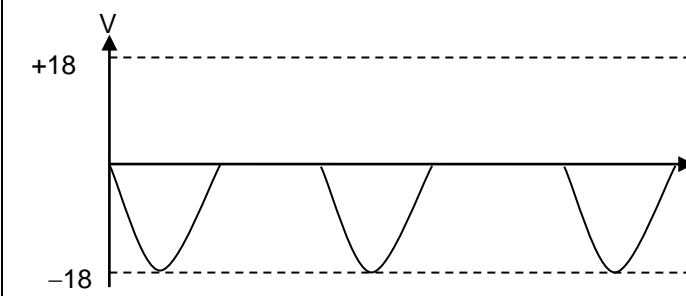
Question 4	MARK SCHEME	KC	UK	XS
<p>(a) (i)</p> <p>(ii)</p>	<p>1 mark for stating: Transformer</p> <p>1 mark for stating: Semiconductor rectifiers, or diodes</p>	1 1		
	<p>1 mark for sketching a sinusoidal waveform 1 mark for indicating peak values at $\pm 120V$</p>  <p>1 mark for sketching a $\frac{1}{2}$-waveform 1 mark for indicating peak values at +18V or -18V e.g.</p>  <p>or</p> 		2 2	

Question 4 Cont'd	MARCH SCHEME	KC	UK	XS																																																												
(b) (i)	1 mark for stating: L, M and N are inputs	1																																																														
(ii)	1 mark for stating: A is an AND gate 1 mark for stating: B is an AND gate 1 mark for stating: A is an OR gate	3																																																														
(iii)	1 mark for correctly completing the outputs of X using gates the student suggested in (b) (ii) 1 mark for correctly completing the outputs of Y using gates the student suggested in (b) (ii) 1 mark for correctly completing the outputs of Z using gates the student suggested in (b) (ii) <i>THE TRUTH TABLE FOR THE COMBINATION OF THE LOGIC GATES IN b(ii) IS SHOWN BELOW.</i> <table border="1" data-bbox="370 1081 1141 1423"> <thead> <tr> <th colspan="3">Input</th> <th colspan="3">Output</th> </tr> <tr> <th>L</th> <th>M</th> <th>N</th> <th>X</th> <th>Y</th> <th>Z</th> </tr> </thead> <tbody> <tr><td>0</td><td>0</td><td>0</td><td>0</td><td>0</td><td>0</td></tr> <tr><td>0</td><td>0</td><td>1</td><td>0</td><td>0</td><td>0</td></tr> <tr><td>0</td><td>1</td><td>0</td><td>0</td><td>0</td><td>0</td></tr> <tr><td>0</td><td>1</td><td>1</td><td>0</td><td>1</td><td>1</td></tr> <tr><td>1</td><td>0</td><td>0</td><td>0</td><td>0</td><td>0</td></tr> <tr><td>1</td><td>0</td><td>1</td><td>0</td><td>0</td><td>0</td></tr> <tr><td>1</td><td>1</td><td>0</td><td>1</td><td>0</td><td>1</td></tr> <tr><td>1</td><td>1</td><td>1</td><td>1</td><td>1</td><td>1</td></tr> </tbody> </table>	Input			Output			L	M	N	X	Y	Z	0	0	0	0	0	0	0	0	1	0	0	0	0	1	0	0	0	0	0	1	1	0	1	1	1	0	0	0	0	0	1	0	1	0	0	0	1	1	0	1	0	1	1	1	1	1	1	1	3	3	
Input			Output																																																													
L	M	N	X	Y	Z																																																											
0	0	0	0	0	0																																																											
0	0	1	0	0	0																																																											
0	1	0	0	0	0																																																											
0	1	1	0	1	1																																																											
1	0	0	0	0	0																																																											
1	0	1	0	0	0																																																											
1	1	0	1	0	1																																																											
1	1	1	1	1	1																																																											
(c)	2 marks for stating two or more points from the list below: 1 mark for stating one point from the list below: <ul style="list-style-type: none"> • Lap tops have become lighter. • Lap tops have become faster. • Built-in video camera and microphones are standard in lap tops. 																																																															

Question 4 Cont'd	MARKSCHEME	KC	UK	XS
	<ul style="list-style-type: none"> • They can connect to the internet from locations where internet is available wirelessly. • Laptops are more efficient • Online communication/games/facebook/social Or any other acceptable response		2	
SP. OBJ	D 5.1, 5.2, 5.4, 5.5, 5.6 Total	6	9	

Question 5		KC	UK	XS
(a) (i)	States/list equipment used: <ul style="list-style-type: none"> • α, β, and γ source; • Detector: GM tube or Cloud Chamber • Metre rule; States all three (2) (2) States any 2 (1) (1) States none (0) (0) <p>Procedure of experiment</p> <ul style="list-style-type: none"> • Places GM tube in front of source, or: Places source inside cloud chamber; (1) • Moves GM tube away from source until no radiation is detected, or: (1) Observes/identifies tracks formed inside chamber • Measures distance between GM tube and source, or: (1) Measures length of tracks 	2		
(ii)	Identifies γ radiation is undeflected (1)	1		
(b) (i)	Beta-decay equation: ${}_{11}^{24}\text{Na} \rightarrow {}_{-1}^0\text{e} + {}_{12}^{24}\text{Mg}$ ${}_{-1}^0\text{e}$ (1) ; ${}_{12}^{24}\text{Mg}$ (2) [1 for Mg and 1 for atomic number and atomic mass]		3	
(ii)	Length of time: <ul style="list-style-type: none"> • Identifies/calculates that $\frac{7}{8}$ of the sample remains: $\frac{21 \text{ grams}}{24 \text{ grams}} = \frac{7}{8}$ (1) • Identifies/calculates that $\frac{1}{8}$ of sample remains: $1 - \frac{7}{8} = \frac{1}{8}$ (1) • Identifies/calculate that 3 half lives have elapsed: $\left(\frac{1}{2}\right)^n = \frac{1}{8}$ $\Rightarrow n = 3$ (1) • Calculates length of time: $n \times \frac{1}{2} = 3 \times 15 \text{ hrs} = 45 \text{ hours}$ (1) 		4	
(iii)	Discussion of safety measure (1) <ul style="list-style-type: none"> • States 1 appropriate safety Measure (1) • Presents reasoned argument why safety measure must be observed (1) argument (1) reasoning 		2	
Sp. Obj	E, 3.3; 3.4; 3.5; 3.6; 3.10	6	9	



TEST CODE **01238032**

FORM 01238032/SPEC

C A R I B B E A N E X A M I N A T I O N S C O U N C I L

**CARIBBEAN SECONDARY EDUCATION CERTIFICATE®
EXAMINATION**

PHYSICS

SPECIMEN PAPER 2012

Paper 032 – General Proficiency

2 hours 10 minutes

READ THE FOLLOWING DIRECTIONS CAREFULLY

1. You **MUST** use this answer booklet when responding to the questions. For each question, write your answer in the space provided and return the answer booklet at the end of the examination.
2. **ALL WORKING MUST BE SHOWN** in this booklet, since marks will be awarded for correct steps in calculations.
3. Attempt **ALL** questions.
4. The use of non-programmable calculators is allowed.
5. Mathematical tables are provided.

DO NOT TURN THIS PAGE UNTIL YOU ARE TOLD TO DO SO

Copyright © 2012 Caribbean Examinations Council ®

All rights reserved

1. In this experiment you are required to investigate the period of a pendulum made from paperclips.

The paperclips provided are to be linked together, in a chain, and swung as a single pendulum, as shown below in Figure 1. The period of the pendulum, T , depends on the number of paperclips, n , linked together.

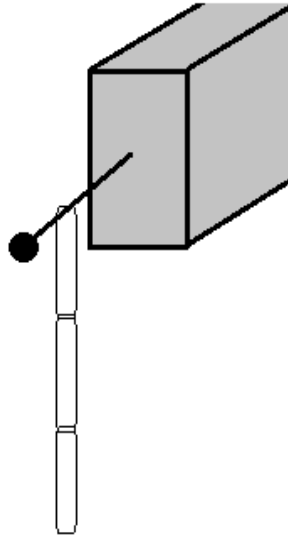

Figure 1

It is suggested that the relationship between T and n is $T = kn$ where k is a constant.

Describe how you would use the paperclips provided to test this theory for $n = 3, 6$ and 9 .

Include in your answer:

- (a) The steps taken in obtaining your results

(6 marks)

(b) A record of the measurements

(5 marks)

(c) Calculations

(7 marks)

(d) Two possible sources of error and the precautions taken

(2 marks)

(e) Conclusion

(4 marks)

Total 24 marks

2. Table 1 shows the relationship between the temperature, T , of the measuring junction of a thermocouple and the thermocouple emf, E , that is measured by a millivoltmeter.

Table 1

Thermocouple emf E (mV)	0.1	0.4	0.7	1.0	1.4	1.8
Temperature T ($^{\circ}\text{C}$)	44	118	163	202	247	293

- (a) (i) Plot on page 5, a graph of the thermocouple emf, E , against Temperature, T . Draw your BEST straight line. **(7 marks)**
- (ii) Find the slope S of the graph.

(6 marks)

- (b) (i) Using the graph determine T_0 , the temperature at which the thermocouple emf $E = 0$ mV

(1 mark)**Total 14 marks**

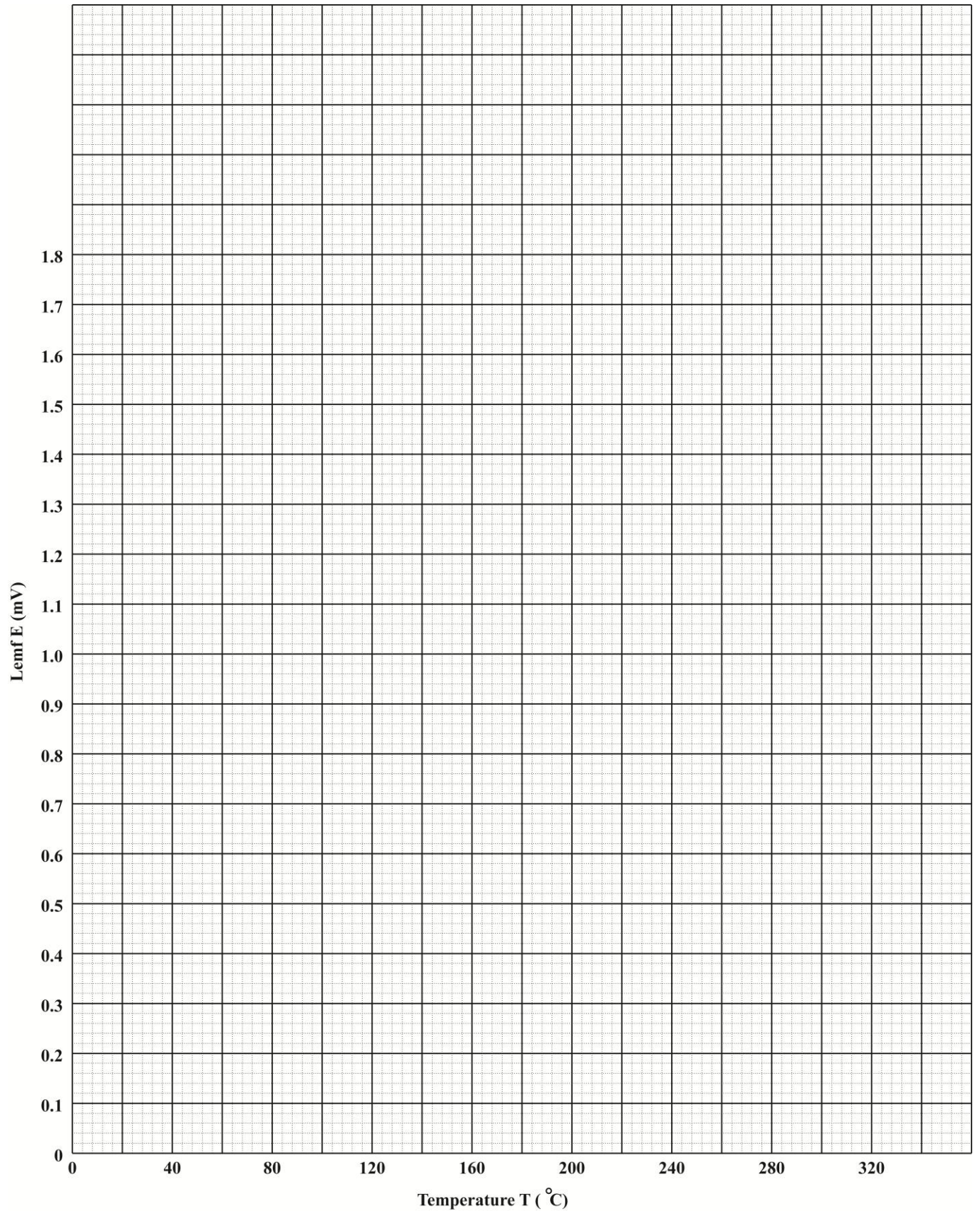

3. In an examination question about refraction, a student draws the diagram below and writes:

“If angle i is doubled, angle r will also be doubled”

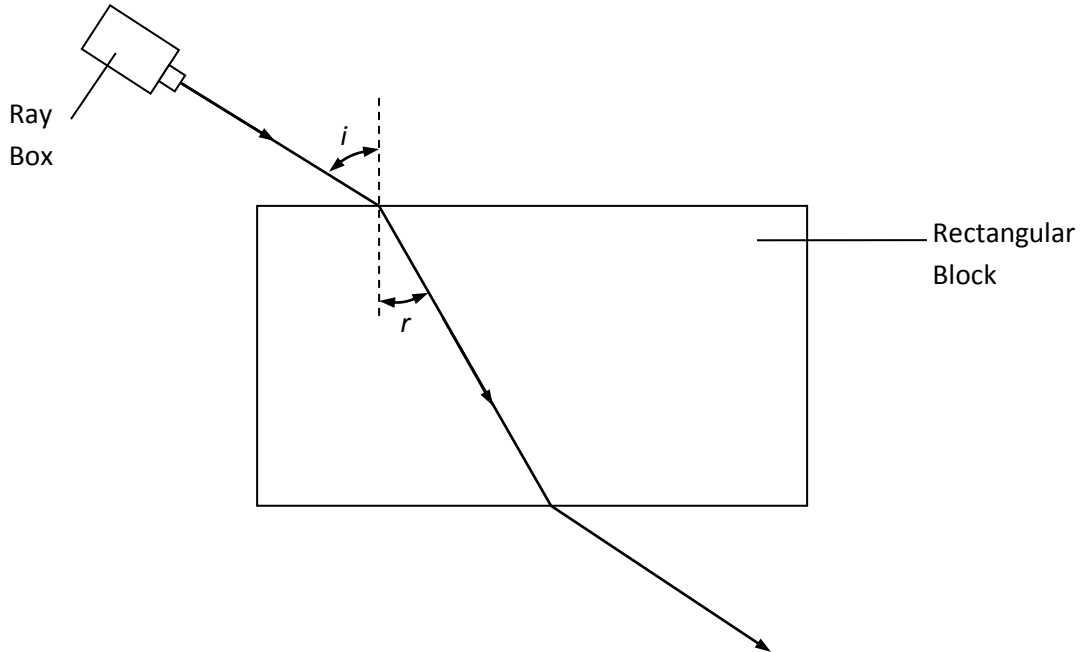

Plan and design an experiment to investigate the student's statement.

Your design must include:

- (a) A clear objective/aim

(1 mark)

(b) A list of equipment used

(2 marks)

(c) Clear procedures in an appropriate sequence

(4 marks)

(d) A statement/explanation of the manipulation of the data collected;

(1 mark)

(e) A precaution taken during investigation;

(1 mark)

(f) One possible limitation of your design.

(1 marks)

Total 10 marks

C A R I B B E A N E X A M I N A T I O N S C O U N C I L

CARIBBEAN SECONDARY EDUCATION CERTIFICATE®
EXAMINATION

PHYSICS

SPECIMEN PAPER

PAPER 032 - GENERAL PROFICIENCY

MARK SCHEME

2012

PHYSICS
PAPER 032 - GENERAL PROFICIENCY
MARK SCHEME

Question No. 1	Mark Scheme	KC	UK	XS
(a)	<p>Method:</p> <ul style="list-style-type: none"> • Pendulum set in motion with small angle of swing (1) • Started count simultaneously with stopwatch (1) • Measured time for X swings (1) • Repetition (1) • Repeat with 6 and 9 paperclips (1) • Use of English - tense (1) 			6
(b)	<p>Table:</p> <ul style="list-style-type: none"> • Neat table (1) • Headings with units for each column (2) • Consistent sig. fig. time column (1) • period column (1) 			5
(c)	<p>Calculations</p> <ul style="list-style-type: none"> • Average time for each length (1) • Period (3 x 1) • k for each set (3 x 1) 		7	
(d)	<p>Possible Sources of error</p> <ul style="list-style-type: none"> • Timing (1) • Angle of release (1) 			2
(e)	<p>Precautions</p> <ul style="list-style-type: none"> • Repetition (1) • Small displacement (1) <p>Conclusion</p> <ul style="list-style-type: none"> • Relates to aim (1) • Valid (1) 			2
Sp. Obj	A 1.2, 1.7, 1.8, 1.9	Total	8	16

PHYSICS
PAPER 032 - GENERAL PROFICIENCY
MARK SCHEME

Question No. 2	MARK SCHEME	KC	UK	XS
(a) (i)	L-Label axes (1) A-Correct orientation of axes (1) S-Scales (1) P-Plots: (3) 6 – 5 correct – 3 4 – 3 correct – 2 2 – 1 correct – 1 Best line (1)			7
(a) (ii)	Large Δ (1) Correct read offs (1) Gradient formula = $\frac{\Delta E}{\Delta T} = \frac{1.86-0}{300-80} = \frac{1.86}{220} = 0.0085 \text{ mV}^\circ\text{C}^{-1}$ (2 s.f.) (3) Answer = _____ ± 0.001 (1)		4	2
(b)	Read off correct value of T (1)			1
Sp. Obj	A 1.4, 1.5; B 2.3	Total	4	10

PHYSICS
PAPER 032 - GENERAL PROFICIENCY
MARK SCHEME

Question 3	MARK SCHEME	KC	UK	XS
(a)	Clear objective/aim: To investigate the relationship between i and r . or To measure r for various i			1
(b)	List of equipment <ul style="list-style-type: none"> • Glass block; • Ray box/plotting pins; • Protractor; • Ruler 	4-3 items (2) 2-1 items (1)		2
(c)	Procedure: <ul style="list-style-type: none"> • Draws outline of block or reference lines and normal; • Shines ray of light for various angles i; • Marks path of light; • Measures angles r. 	4 steps (3) 3 step (2) 2-1 step (1) App. Seq. (1)		4
(d)	Manipulation of data <ul style="list-style-type: none"> • States that i and r are compared; or • States that a graph of r vs. i is plotted and explains the use of the graph in the analysis of i and r; or • Any other reasonable analysis of data 	(1)		1
(e)	Precaution States one reasonable precaution	(1)		1
(f)	Limitation States one reasonable limitation of method	(1)		1
Sp. Obj	C 4.4, 4.8	Total		10